

Product Catalogue

PT Waskita Beton Precast Tbk





SEBAB UTAMA KECELAKAAN

KECEROBHAN DAN KELALAIAN

SEBAB UTAMA KECELAKAAN

WASKITA
precast



Anak Agung Gede Sumadi
President Director

Foreword

We are pleased to present the PT Waskita Beton Precast Tbk (WSBP) Product Catalogue. This catalogue is a reflection of our commitment in providing high quality Precast and Readymix concrete products designed to meet the needs of various infrastructure projects throughout Indonesia. It contains a variety of our superior products, which have been designed with the latest technology and produced in accordance with standards.

As a company that always strives to deliver the best, we understand that the success of infrastructure projects is not only determined by the quality of materials used, but also by innovation and timeliness in product delivery.

Amidst the challenges and dynamics of the construction industry, we continue to innovate to bring more efficient and environmentally friendly solutions. The products we offer in this catalog are the result of the dedication and hard work of our entire team, who are always committed to raising the quality standards in the Precast and Readymix concrete industry. We believe that with our quality-oriented approach, WSBP will continue to be the first choice for construction industry players.

Finally, we would like to thank all our partners and customers for their trust and support. Hopefully, this catalog can be a useful guide in determining the best product choice for your project. We look forward to continue working together and making a positive contribution to Indonesia's infrastructure development.

Table of Content

Foreword	ii
Table of Content	iii
Location	iv

Bina Marga 7

Girder	Box Girder	8
	PC-I Girder	12
	PC-U Girder	17
	PC-T Girder	21
Pile	Spun Pile	25
	Square Pile	32
Slab	Full Slab	36
	Half Slab	40
	Voided Slab	42
SPRigWP	45	
Movable Concrete Barrier (MCB)	48	
Concrete Sleeper for Railway (BJR)	50	
Electric Poles	52	

Irrigation 55

CCSP	56
FCSP & FRSP	62
Tetrapod	65
RC Pipe	68
Lining	72
Sloof Irigrasi	75
U-Ditch & Cover	78
Box Culvert	81

Housing & Building 85

Beam-Column Precast	86
Facade	88
Modern Precast House	90
Modified RISHA	93
Modular i-MOD	96
Modular i-Home	107

Readymix Concrete 109





Operation Area



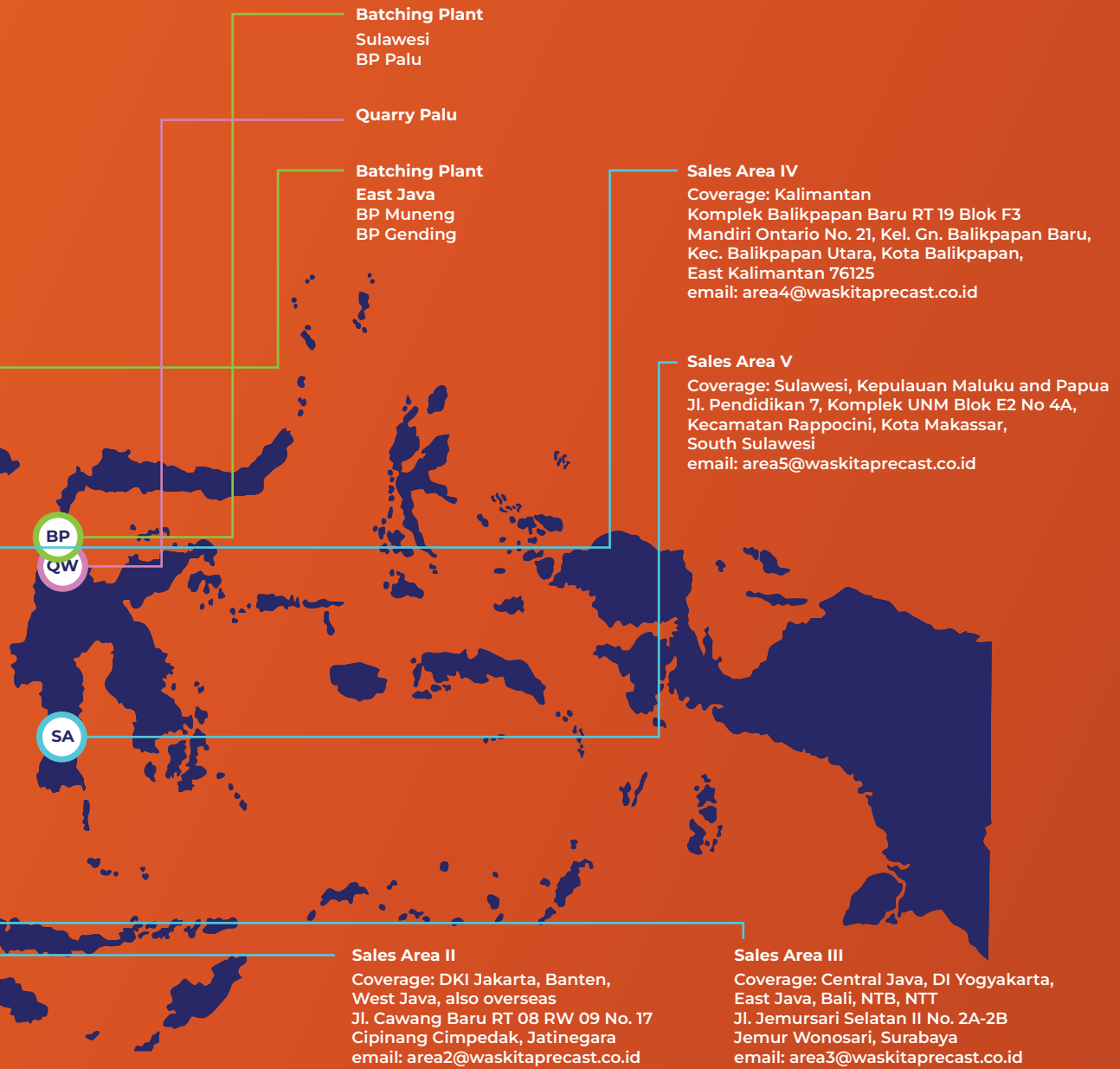

-  **HO** Head Office
-  **P** Precast Plant
-  **BP** Batching Plant
-  **QW** Quarry & Workshop
-  **SA** Sales Area

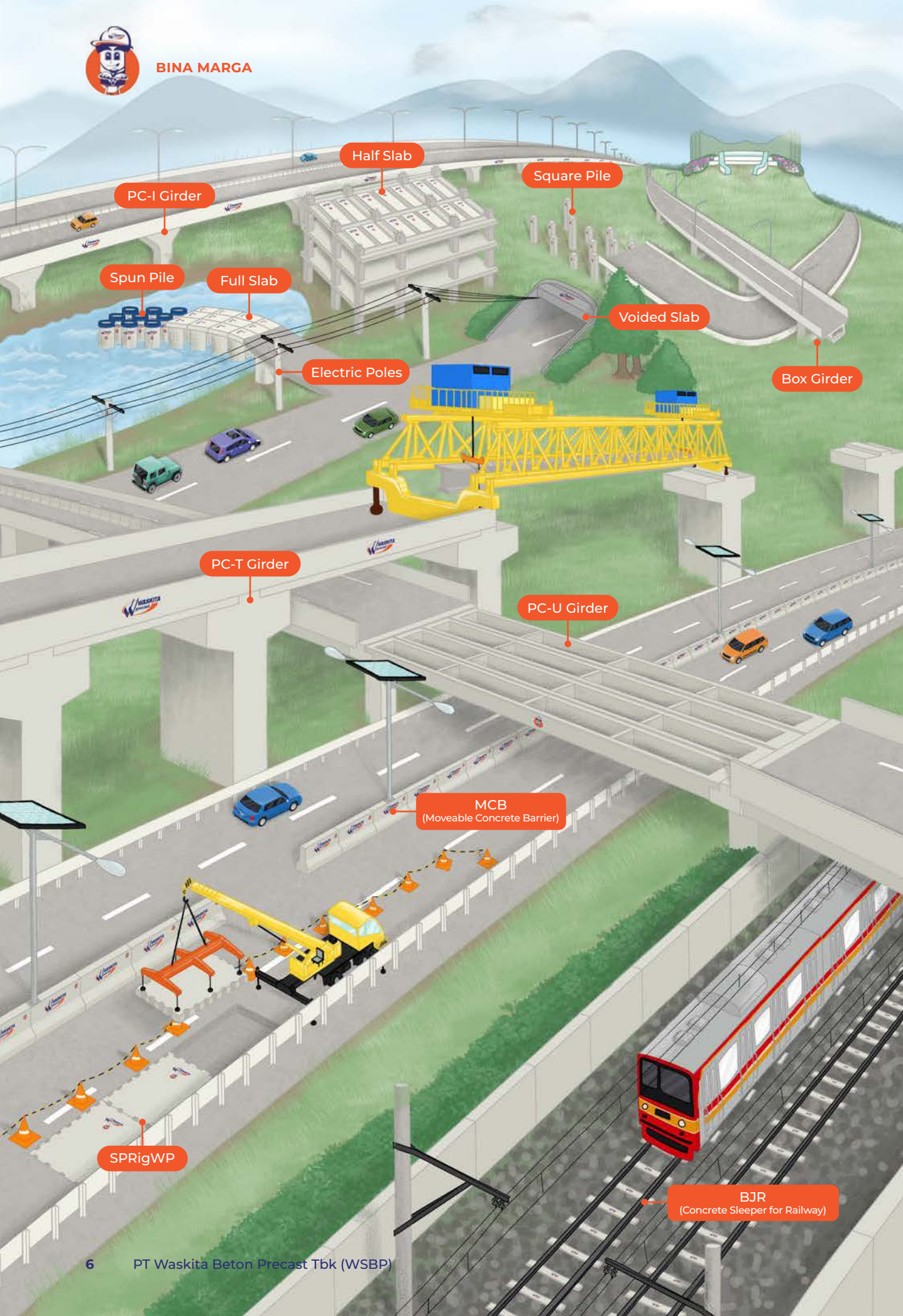

PC-I Girder

Half Slab

Square Pile

Spun Pile

Full Slab

Voided Slab

Electric Poles

Box Girder

PC-T Girder

PC-U Girder

MCB
(Moveable Concrete Barrier)

SPRigWP

BJR
(Concrete Sleeper for Railway)

Bina Marga

Girder Box Girder
 PC-I Girder
 PC-U Girder
 PC-T Girder

Pile Spun Pile
 Square Pile

Slab Full Slab
 Half Slab
 Voided Slab

SPRigWP

Movable Concrete Barrier (MCB)

Concrete Sleeper for Railway (BJR)

Electric Poles



Box Girder

Segmental beam product that has a hollow cross section in the middle. The purpose of this hollow cross section is for efficiency. The advantage of the Box Girder is that isn't necessary to cast a deck. So that after the erection, it can proceed to the stage of pavement work or the installation of railroad tracks.

Technical

Prestressing System

Post-Tension

Erection Method

- Span by Span
- Balance Cantilever

Production System

- Long Line
- Match Case

Design & Manufacturing Reference

RSNI T-02-2005	Load-Bearing Standards for Bridge Construction
BMS 7	Bridge Design Code
AASHTO - 2002	Standard Specification for Highway Bridge
ACI 318-2011	Building Code Requirement for Structural Concrete
SNI 03-2847-2013	Indonesian Concrete Code
PCI MnI-133	Bridge Design Manual

Specification of Source Material

Item	Specification	Reference
Aggregate	ASTM C33 - 2016	Standard Specification Concrete Aggregates
	SNI 8321-2016	Concrete Aggregate Specification
Cement	SNI 15-2049-2004	Portland's Cement

Admixture		ASTM C494 - 2016	Standard Specification for Chemical Admixture for Concrete
Concrete	Compressive Strength at : 28 Days : 600 kg/cm ² (Cube); 50 MPa (Cylinder)	SNI 2847-2013	Structural Concrete Requirement
Reinforced Rebar	BjTS 40 For D ≥ 13mm BjTP 24 For D < 13mm	SNI 2052-2014	Concrete Reinforcement Steel Bar
PC Strand	KBjP-P7 RB	SNI 1154-2011	Uncoated Seven Wire Stress Relieved Strand for Prestress Concrete (Pc Strand/ KBjP-P7)
	Grade 270	ASTM A-416	Standard Specification for Uncoated Seven_ Wire Stress Relieved Strand for Prestressed Concrete
	SWPR7BL	JIS G 3536 : 2014	Uncoated Stress-Relieved Steel Wires and Strands for Prestressed Concrete
Post Tension System	VLM System		
	DSI System		
Post Tension Grout	Compressive Strength : at 7 Day : 27 MPa at 28 Day : 30 MPa	BS EN 447 : 2007	Grout for Prestressing Tendon. Basic Requirement

Product Type

Typical Segment

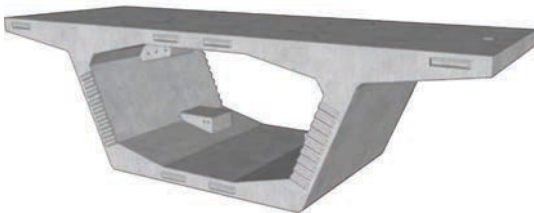

Expansion Joint Segment



Product Dimension

Type 1

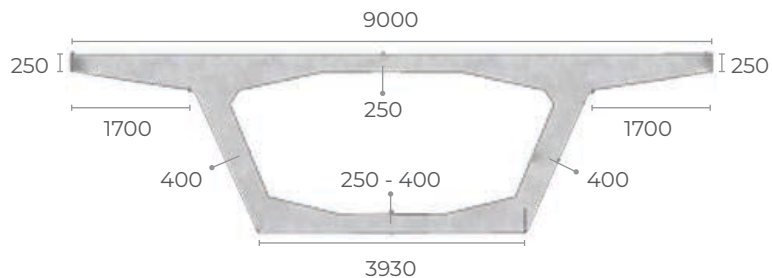



Type 2

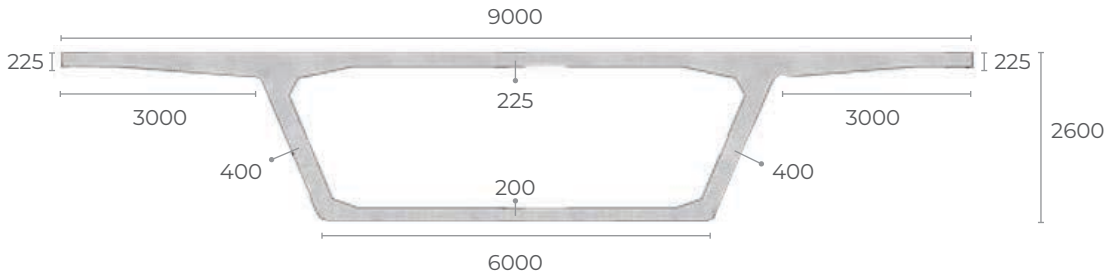

Dimension can be modified based on user needs.
All units in mm.

Erection Method

Balance Cantilever

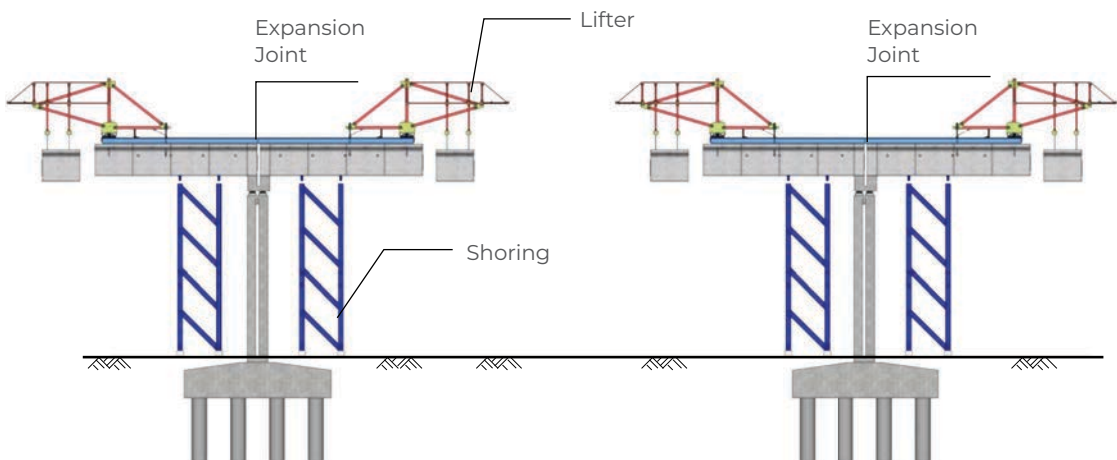

Span by Span

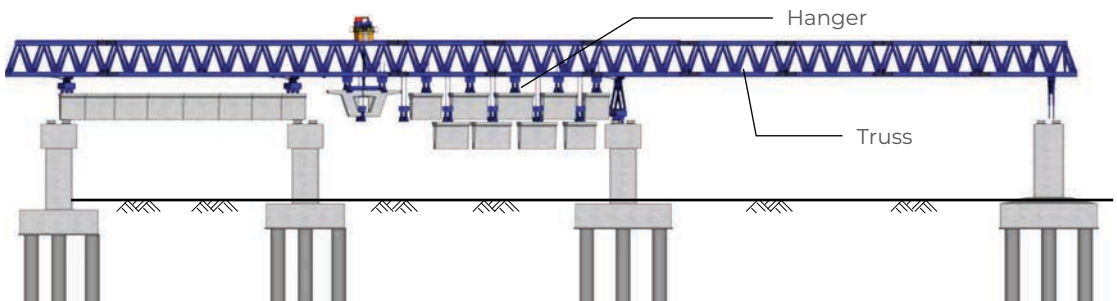





BINA MARGA



PC-I Girder

Precast beam girder that use "I" shape section, "I" shape section causes beam to have greater I_x (Inertia of x Axis) on same cross sectional area, so beam girder become more efficient on economical. This PC-I Girder can be used on bridge for road or railway.

Technical

Type of Girder

PC-I Girder

Erection Method

- Launching Gantry
- Launching Truss
- Double Crane
- Single Crane (Max. 15 m)

Prestressing System

Post Tension, Pre Tension

Production System

Segmental, Non Segmental

Design & Manufacturing Reference

RSNI T-02-2005	Load-Bearing Standards for Bridge Construction
BMS 7	Bridge Design Code
AASHTO - 2002	Standard Specification for Highway Bridge
ACI 318-2011	Building Code Requirement for Structural Concrete
SNI 03-2847-2013	Indonesian Concrete Code
PCI MnI-133	Bridge Design Manual

Specification of Source Material

Item	Specification	Reference
Aggregate	ASTM C33 - 2016	Standard Specification Concrete Aggregates
	SNI 8321-2016	Concrete Aggregate Specification
Cement	SNI 15-2049-2004	Portland's Cement

Admixture		ASTM C494 - 2016	Standard Specification for Chemical Admixture for Concrete
Concrete	Compressive Strength at : 28 Days : 500 - 800 kg/cm ² (Cube); 42 - 65 MPa (Cylinder) depends on beam span	SNI 2847-2013	Structural Concrete Requirement
Reinforced Rebar	BjTS 40 For D ≥ 13mm BjTP 24 For D < 13mm	SNI 2052-2014	Concrete Reinforcement Steel Bar
PC Strand	KBjP-P7 RB	SNI 1154-2011	Uncoated Seven Wire Stress Relieved Standard for Prestress Concrete (Pc Strand/ KBjP-P7)
	Grade 270	ASTM A-416	Standard Specification for Uncoated Seven_ Wire Stress Relieved Strand for Prestressed Concrete
	SWPR7BL	JIS G 3536 : 2014	Uncoated Stress-Relieved Steel Wires and Strands for Prestressed Concrete
Post Tension System	VLM System		
	DSI System		
Post Tension Grout	Compressive Strength : at 7 Day : 27 MPa at 28 Day : 30 MPa	BS EN 447 : 2007	Grout for Prestressing Tendon. Basic Requirement
Pin Connector	S45C	JIS G 4051:2009	Carbon Steel for Machine Structural
	C45	DIN EN 10083-2:2006-10	Steel for Quenching and Tempering

Product Type

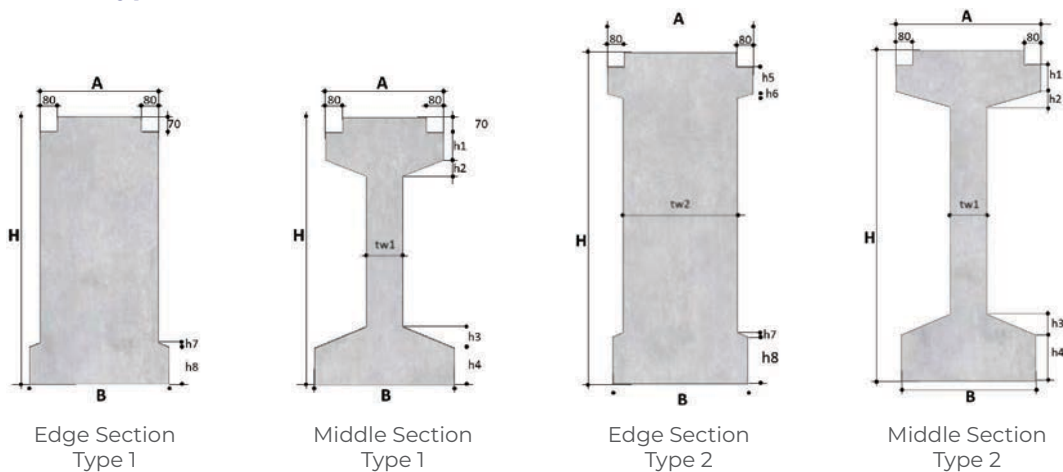

All units in mm



Product Dimension

Notation	Unit (mm)	H (cm)								
		Type 1		Type 2						
		90	125	140	160	170	185	210	230	Semi-T
A	mm	550	550	700	700	800	800	800	850	1200
B	mm	650	650	650	650	700	700	700	750	750
Tw1	mm	170	170	180	180	200	200	200	250	250
Tw2	mm	-	-	550	550	600	600	600	600	650
h1	mm	130	130	130	130	130	130	130	130	100
h2	mm	75	75	75	75	120	120	120	120	170
h3	mm	100	100	100	100	250	250	250	250	250
h4	mm	125	125	225	225	250	250	250	250	250
h5	mm	-	-	130	130	130	130	130	130	100
h6	mm	-	-	22	22	40	40	40	40	105
h7	mm	21	22	21	22	50	50	50	50	50
h8	mm	125	175	225	225	250	250	250	250	250

Typical of Girder according to length:

1. Span 16 m, H 90
2. Span 20 m, H 125
3. Span 25 m, H 160
4. Span 30 m, H 170
5. Span 40 m, H 210
6. Span 45 m, H 210
7. Span 50 m, Semi-T

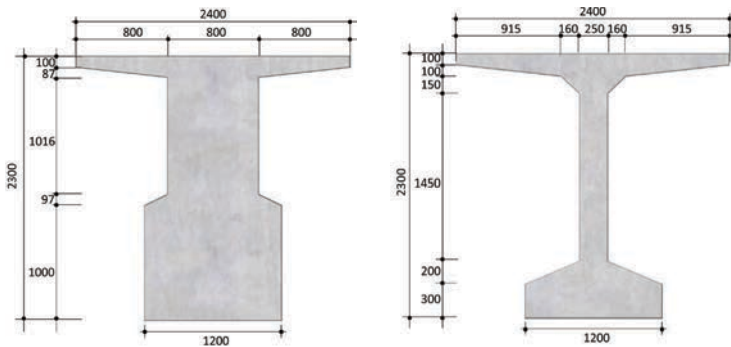

Another Available Length

Notation	Unit (mm)	H (cm)								
		Type 1		Type 2						
		90	125	140	160	170	185	210	230	Semi-T
Span (K-800)	m	16 to 19	16 to 28	16 to 35	24 to 43	35 to 44	37 to 48	38 to 52	45 to 52	Max 50 m
Span (K-500)	m	16 to 18	16 to 24	16 to 28	20 to 33	27 to 40	29 to 42	32 to 45	37 to 48	

Recommended CTC (Center to Center) Spacing : 1,4 m ; 1,85 m ; 2,1 m ; 2,4 m
But another CTC Spacing can be accomodated

Segmental Connection Detail



Alt. 1 Shear Key
(Match Casting)



Alt. 2 Pin Connector Typical
(Direct Casting)



Alt. 1 Embedded Wire Rope

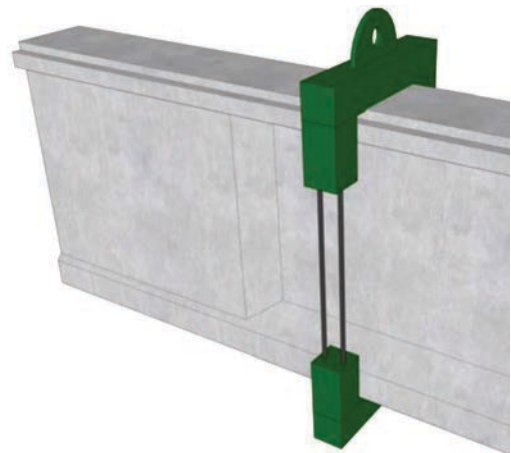

Alt. 2 Using Steel Girder Lifter

This system will increase stability while erection process, because turning point positioned above centroid.



BINA MARGA





PC-U Girder

Precast beam Girder that use “U” shape section, “U” shape section causes beam to have greater I_y (Inertia of y Axis) on same cross sectional area, so lateral stability is increased, make erection team more confidence while lifting this product. This PC-U Girder can be used on bridge for road or railway.

Technical

Type of Girder

PC-U Girder

Erection Method

- Launching Gantry
- Launching Truss
- Double Crane
- Single Crane (Max. 15 m)

Prestressing System

Post Tension, Pre Tension

Production System

Segmental, Non Segmental

Design & Manufacturing Reference

RSNI T-02-2005	Load-Bearing Standards for Bridge Construction
BMS 7	Bridge Design Code
AASHTO - 2002	Standard Specification for Highway Bridge
ACI 318-2011	Building Code Requirement for Structural Concrete
SNI 03-2847-2013	Indonesian Concrete Code
PCI MnI-133	Bridge Design Manual
SNI 9156 2023	Specifications for prestressed hollow circular section piles
SNI 9157 2023	Corrugated concrete sheet pile specifications for soil retaining systems



Specification of Source Material

Item	Specification	Reference
Aggregate		ASTM C33 - 2016 Standard Specification Concrete Aggregates
		SNI 8321-2016 Concrete Aggregate Specification
Cement		SNI 15-2049-2004 Portland's Cement
Admixture		ASTM C494 - 2016 Standard Specification for Chemical Admixture for Concrete
Concrete	Compressive Strength at : 28 Days : 500 - 800 kg/cm ² (Cube); 42 - 65 MPa (Cylinder) depends on beam span	SNI 2847-2013 Structural Concrete Requirement
Reinforced Rebar	BJTS 40 For D ≥ 13mm	SNI 2052-2014 Concrete Reinforcement Steel Bar
	BJTP 24 For D < 13mm	
PC Strand	KBjP-P7 RB	SNI 1154-2011 Uncoated Seven Wire Stress Relieved Standard for Prestress Concrete (Pc Strand/ KBjP-P7)
	Grade 270	ASTM A-416 Standard Specification for Uncoated Seven_ Wire Stress Relieved Srand for Prestressed Concrete
	SWPR7BL	JIS G 3536 : 2014 Uncoated Stress-Relieved Steel Wires and Strands for Prestressed Concrete
Post Tension System	VLM System	
	DSI System	
Post Tension Grout	Compressive Strength : at 7 Day : 27 MPa at 28 Day : 30 MPa	BS EN 447 : 2007 Grout for Prestressing Tendon. Basic Requirement
Pin Connector	S45C	JIS G 4051:2009 Carbon Steel for Machine Structural
	C45	DIN EN 10083-2:2006-10 Steel for Quenching and Tempering

Product Dimension

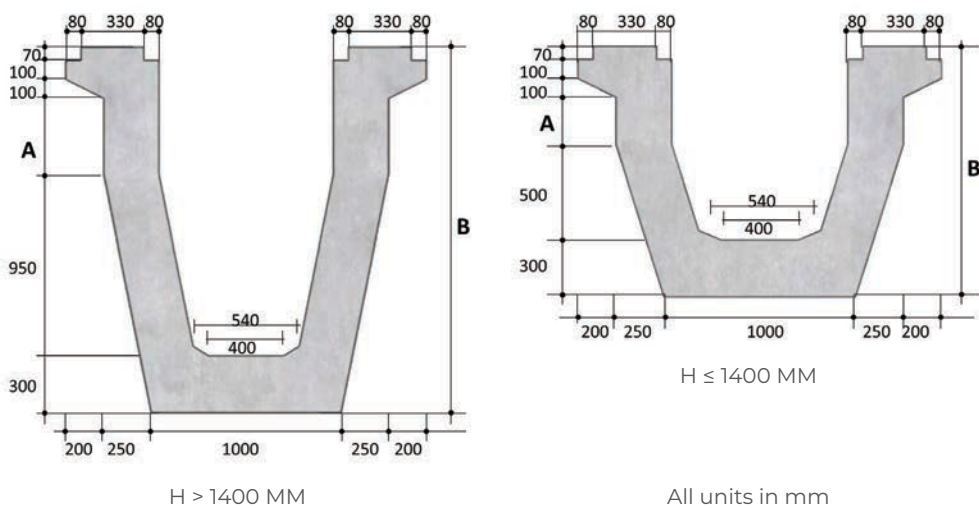

Type	A (mm)	B (mm)
H-120	130	1200
H-130	230	1300
H-140	330	1400
H-165	130	1650
H-175	230	1750
H-185	330	1850
H-220	680	2200
H-240	880	2400

Typical of Girder according to length:

1. Span 20 m, H-120
2. Span 25 m, H-130
3. Span 30 m, H-140
4. Span 32 m, H-165
5. Span 35 m, H-185
6. Span 40 m, H-185
7. Span 50 m, H-220
(Special Order)

Another Available length

Type	A (mm)	B (mm)
H-120	130	1200
H-130	230	1300
H-140	330	1400
H-165	130	1650
H-175	230	1750
H-185	330	1850
H-220	680	2200
H-240	880	2400

Recommended CTC Spacing (Center to Center) : 3,1 m
But another CTC Spacing can be accomodated



BINA MARGA





PC-T Girder

Precast beam Girder that use “T” shape section, “T” shape section causes beam to have greater ly (Inertia of y Axis) on same cross sectional area, so lateral stability is increased, make erection team more confidence while lifting this product. This PC-T Girder can be used on bridge for road or railway.

Technical

Type of Girder

PC-T Girder

Prestressing System

Post Tension, Pre Tension

Production System

Segmental, Non Segmental

Erection Method

- Launching Gantry
- Launching Truss
- Double Crane
- Single Crane (Max. 15 m)

Design & Manufacturing Reference

RSNI T-02-2005	Load-Bearing Standards for Bridge Construction
BMS 7	Bridge Design Code
AASHTO - 2002	Standard Specification for Highway Bridge
ACI 318-2011	Building Code Requirement for Structural Concrete
SNI 03-2847-2013	Indonesian Concrete Code
PCI MnI-133	Bridge Design Manual

Specification of Source Material

Item	Specification	Reference
Aggregate	ASTM C33 - 2016	Standard Specification Concrete Aggregates
	SNI 8321-2016	Concrete Aggregate Specification



Cement		SNI 15-2049-2004	Portland's Cement
Admixture		ASTM C494 - 2016	Standard Specification for Chemical Admixture for Concrete
Concrete	Compressive Strength at : 28 Days : 800 kg/cm ² (Cube); 65 MPa (Cylinder) depends on beam span	SNI 2847-2013	Structural Concrete Requirement
Reinforced Rebar	BJTS 40 For D ≥ 13mm BJTP 24 For D < 13mm	SNI 2052-2014	Concrete Reinforcement Steel Bar
PC Strand	KBjP-P7 RB	SNI 1154-2011	Uncoated Seven Wire Stress Relieved Standard for Prestress Concrete (Pc Strand/ KBjP-P7)
	Grade 270	ASTM A-416	Standard Specification for Uncoated Seven_ Wire Stress Relieved Strand for Prestressed Concrete
	SWPR7BL	JIS G 3536 : 2014	Uncoated Stress-Relieved Steel Wires and Strands for Prestressed Concrete
Post Tension System	VLM System		
	DSI System		
Post Tension Grout	Compressive Strength : at 7 Day : 27 MPa at 28 Day : 30 MPa	BS EN 447 : 2007	Grout for Prestressing Tendon. Basic Requirement
Pin Connector	S45C	JIS G 4051:2009	Carbon Steel for Machine Structural
	C45	DIN EN 10083-2:2006-10	Steel for Quenching and Tempering

Product Dimension

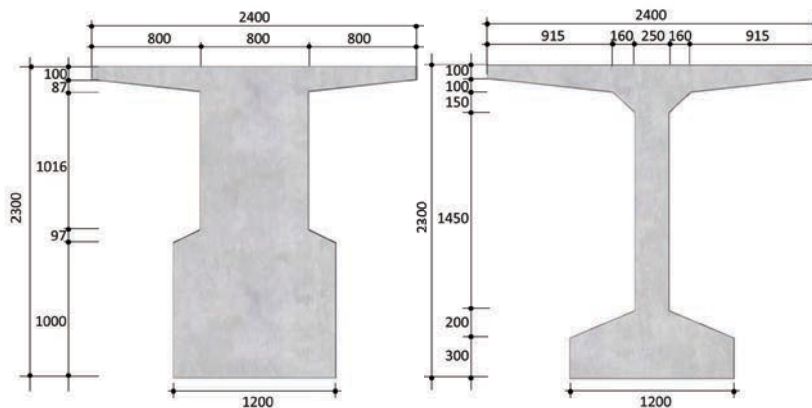

All units in mm

Recommended Specification:

Span : 50 – 60 m
 CTC (Center to Center) Spacing : 2,5 m





Innovation Design

Semi T Girder

The innovation carried out is to make improvements to the widening of the upper wing of the PC-I Girder cross section so that it looks like a Semi T profile.

Basically, the improvement of the standard PC-I Girder cross section to Semi T can increase the inertial capacity of the cross section, especially laterally so that it can be directed without stiffeners.

By making improvements to the girder cross section, it can increase the inertia value in both vertical and horizontal directions. So that the increase in cross-sectional inertia is expected to increase the stiffness of the girder beam.

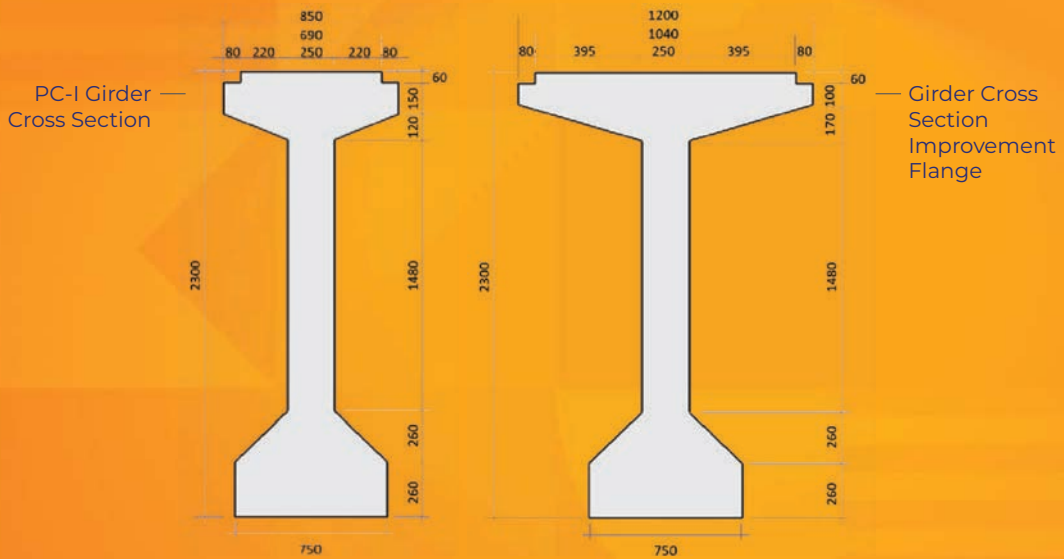

Moment of Inertia	Existing Girder Cross Section	Girders Cross Section Improvement	Deviation (%)
Vertical directional inertia, I_x (cm ⁴)	57,477,847	65,242,809	14
Horizontal directional inertia, I_y (cm ⁴)	2,469,943	4,651,380	88





Spun Pile

Pile that capable to support axial forces, and bending moment. This product have advantages in bending moment capacity. This product suitable to use in structure with dominant lateral forces such as bridges and docks. For Spun Pile with C-T Connection, this product can be used as retaining wall strucutre. This product can also to be used on another structure.

Technical

Type of Pile

Prestressed Concrete Spun Pile

Joint System

Welded at joint Plate

Type of Shoes

- Pencil (Typical Product)
- Mamira (By Order)
- Cross Shoe (By Order)

Method of Driving

- Diesel or Hydraulic
- Hammer Hydraulic
- Static Pile Driving
- Innerboring

Advantage

1. Simple
2. Fast
3. Flexible
4. Environment Friendly
5. Powerful and Durable
6. High Quality

Design & Manufacturing Reference

SNI 9156:2023 Indonesian Concrete Code

Specification of Source Material

Item	Specification	Reference
Aggregate	ASTM C33 - 2016	Standard Specification Concrete Aggregates
	SNI 8321-2016	Concrete Aggregate Specification
Cement	SNI 15-2049-2004	Portland Cement
Admixture	ASTM C494 - 2016	Standard Specification for Chemical Admixture for Concrete



Concrete	Compressive Strength at : 28 Days : 600 kg/cm ² (Cube), 50 MPa (Cylinder)	SNI 2847-2013	Structural Concrete Requirement
PC Wire	SBPDL 1275/1420	JIS G 3536 : 2008	Steel Wires and Strand for Prestressed Concrete
	KBjP-R	SNI 1155 : 2011	Uncoated Steel Wire for Prestress Concrete (KBjP/ PcWire)
PC Bar	SWPD-1	JIS G 3137 : 2008	(Small Diameter Steel Bars for Prestressed Concrete)
	KBjP-Q RI	SNI 7701 : 2011	Quench Steel Bar for Precast Concrete (PC Bar/KBjP-Q)
Spiral Wire	SWM-A / SWM-P	JIS G 3532 : 2011	Low Carbon Steel Wires
Join Plate	SS400	JIS G 3101 : 2011	Roled Steel for General Structure
Mamira Shoes	SS400	JIS G 3101 : 2011	Roled Steel for General Structure
C-T Connector	For Female Connector : Steel Pipe Ø165,2 x 12 (SS400)	JIS G 3101 : 2011	Roled Steel for General Structure
	For Male Connector : "T" Profile Steel (SS400)		
Welding	AWS E7016 (For joining Spun Pile)	AWS D1.1 : 2000	Structural Welding Code - Steel
	AWS E6013 (For Installing C-T Connector)		

Type of Pile

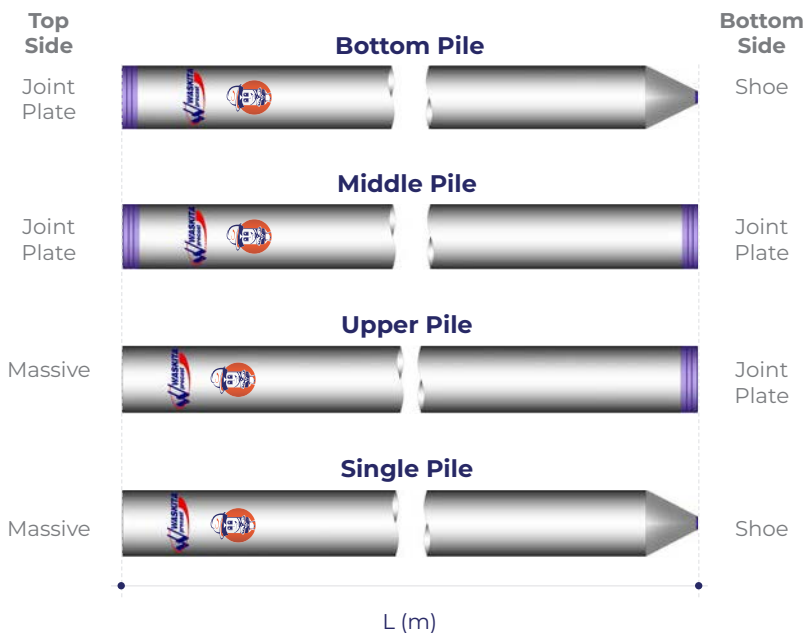

Type of Shoes



Product Dimension

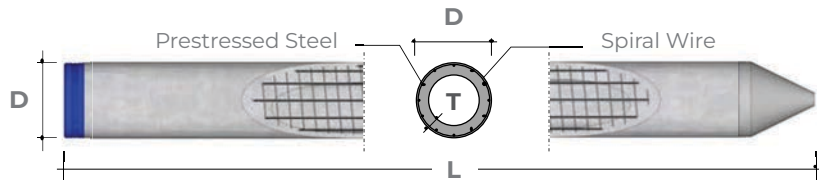

Compressive Strength at 28 Days : 600 kg/cm² (Cube), 50 MPa (Cylinder)

Outsided Diameter D (mm)	Wall Thickness T (mm)	Class	Concrete Cross Section (cm ²)	Unit Weight (kg/m)	Length L (m)	Bending Moment		Allowable Axial Load (kN)
						Crack (kN.m)	Ultimate (kN.m)	
300	60	A2	452	113	6-13	26.9	50.6	698
		A3				29.4	60.4	681
		B			6-15	34.3	69.3	665
		C				39.2	83.8	636
350	65	A1	582	145	6-13	34.3	48.8	937
		A3				44.1	86.8	884
		B			6-16	49.0	97.8	867
		C				58.9	121.7	828
400	75	A2	766	191	6-13	54.0	89.4	1,214
		A3				63.8	118.2	1,178
		B			6-17	73.6	155.7	1,128
		C				88.3	183.8	1,087
450	80	A1	930	232	6-15	73.6	110.9	1,494
		A2				83.4	139.1	1,457
		A3			6-18	98.1	186.3	1,405
		B				107.9	214.1	1,373
500	90	C	1,159	290	6-19	122.6	260.0	1,314
		A1				103.0	159.9	1,848
		A2			6-16	122.6	216.2	1,794
		A3				137.3	250.9	1,759
600	100	B	1,571	393	6-17	147.2	283.0	1,726
		C				166.8	353.5	1,648
		A1			6-21	166.8	251.4	2,514
		A2				186.4	298.2	2,476
800	120	A3	2,564	641	6-17	215.8	409.7	2,388
		B				245.2	473.2	2,336
		C			6-24	284.5	581.4	2,239
		A1				392.4	594.7	4,078
1000	140	A2	3,782	946	6-20	451.3	745.3	3,990
		A3				500.3	886.4	3,906
		B			6-28	539.6	1,044	3,809
		C				637.6	1,311	3,625
1000	140	A1	3,782	946	6-23	735.8	1,123	6,009
		A2				804.4	1,316	5,921
		A3			6-28	912.3	1,591	5,794
		B				1,030	1,904	5,643
		C			1,177	2,372	5,422	



1200	150	A1	4,948	1,237	6-26	1,177	1,816	7,850
		A2				1,275	2,284	7,675
		A3				1,422	2,640	7,538
		B				1,668	3,504	7,226
		C				1,962	3,939	7,041

Joint System

Illustration for two jointed Spun Pile

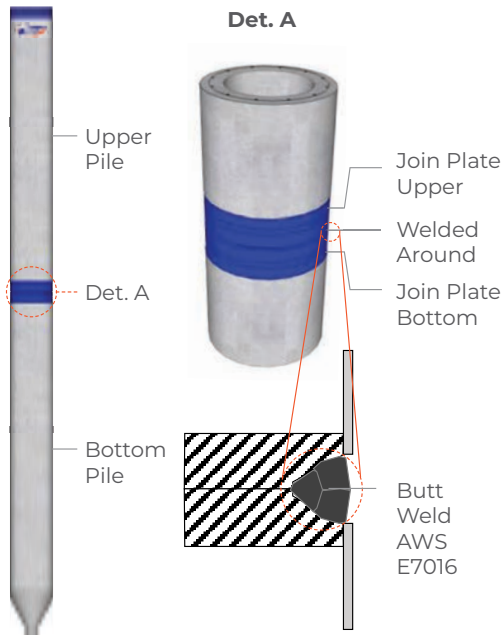

Guide For Choosing Hammer Type

Step 1

Calculate Cylinder Weight

$$W = 0.5 P + 600$$

$$P = P_m L$$

- W : Cylinder Weight (kg)
- P : Pile Weight (kg)
- P_m : Pile Unit Weight (kg/m)
- L : Pile Length (m)

Source : Buku Pondasi Tiang Pancang.
Vol. I, Ir. Sardjono HS

Step 2

Choose Diesel Hammer Type

Type	Cylinder Weight (kg)	Max. Cyl Stroke (m)	Frequency (Times/min)
DD18	1,800	2.1	40 - 60
DD25	2,500	2.5	40 - 50
DD32	3,200	2.5 / 30	40 - 50
DD40	4,000	2.5 / 30	35 - 50
DD53	5,300	2.5 / 30	45 - 50
DD63	6,300	2.5 / 30	35 - 50
DD73	7,300	2.5 / 30	35 - 50
DD83	8,300	2.5 / 30	35 - 50
DD103	10,300	2.5 / 30	35 - 50
DD113	11,300	2.5 / 30	35 - 50
DD128	12,800	2.5 / 30	35 - 50
DD160	16,000	2.5 / 30	36 - 50
DD180	18,000	2.5 / 30	37 - 50
DD200	20,000	2.5 / 30	38 - 50

Type of Lateral Connection (By Order)



Isometric

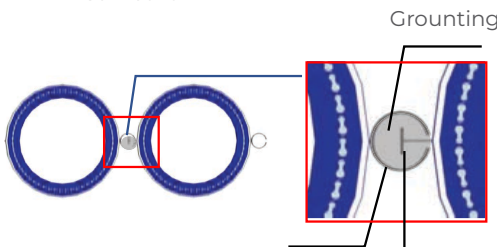

C-T Connector for D800 to D1200

C Connector

T Connector

Bearing Capacity Estimation

Based on : SE PUPR; No. 31/SE/M /2015

Hilley Equation

$$P_u = \frac{e_f \times w \times H}{s + (c_1 + c_2 + c_3)/2} \cdot \frac{W \times n^2 W_p}{W + W_p}$$

$$P_a = \frac{P_u}{N}$$

Calendering Graph Interpretation

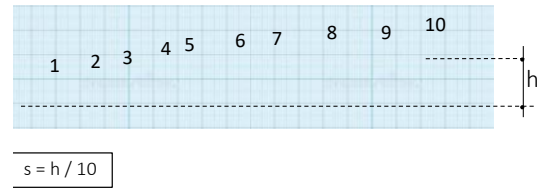

Other Equation

Type of Hammer	Type of Pile	Common Equation
Gravity	Steel, steel sheet	$P_u = \frac{3WH}{S + 0,35} \left(\frac{W}{W + X} \right)$
Steam (Single Act.)	All Type	$P = \frac{2WH}{S + 0,1}$
Steam (Double Act.)	All Type	$P = \frac{2E}{S + 0,1}$
Diesel Hammer	All Type	$P = \frac{1,6E}{S + 0,1 \left(\frac{x}{W} \right)}$

* For diesel hammer, if (X/W) value less than 1, took 1 value

H	: Ram Stroke
s	: Penetration per Blow
W	: Ram Weight
Wp	: Pile Weight
ef	: Hammer Efficiency (See Table 1)
n	: Restitution Coefficient (See Table 3)
C1	: Immediate stress that permitted on pile head (See Table 2)
C2	: Immediate stress that permitted for elastic deformation on pile (See Table 4)
C3	: Immediate stress that permitted for earthquake on site (See Table 4)
N	: Safety factor (N=3)

Table 1

Hammer Type	Efficiency (ef)
Drop Hammer	0.75 - 1.00
Single Act. Hammer	0.75 - 0.85
Double Act. Hammer	0.85
Diesel Hammer	0.85 - 1.00

Table 2

Material	C1 (mm)			
	Driving Stress on Pile Head			
	3.5 MPa	7.0 MPa	10.5 MPa	14.0 MPa
Pole or steel pipe				
• Direct on pile head	0	0	0	0
• Direct on wooden pile head	1	1	3	5
Precast concrete pile with 75 – 100 mm cap thickness	3	6	9	12.5



Steel cap that contain wood for H-Steel pile or steel pipe pile	1	2	3	4
Cap block that contain 5 mm fiber component between two 10mm thickness steel plate	0.5	1	1.5	2

Table 3

Material	n
Wooden Pile	0.25
Wooden Bearing above Steel Pile	0.32
Wooden Bearing on Steel Pile	0.4
Steel Pile without wooden bearing / Concrete Pile with bearing	0.5
Cast iron hammer above concrete pile without cap	0.4

Table 4

Stress	Material	Easy Driving	Medium Driving	Hard Driving	Very Hard Driving
Pile Length, c2	Wooden Pile(E = 10 kN/mm ²)	0.33 L	0.67 L	1.0L	1.3 L
	Precast Concrete Pile(E = 14 kN/mm ²)	0.25 L	0.5 L	0.75 L	1.0 L
	Steel Pile(E = 200 kN/mm ²)	0.25 L	0.5 L	0.75 L	1.0 L
Earthquake, c3	Soil around pile and below pile	1.3	1.3 - 2.5	3.8 - 6	1.3 - 3.8





Square Pile

Pile that capable to support axial force, and bending moments. Pile that have dominant axial force capacity. Generally used for building foundations, and also other structure with dominant axial forces.

Technical

Type of Pile

Prestressed Concrete Square Pile

Type of Shoes

Pencil (Typical Product)

Joint System

Welded at Steel joint Plate

Method of Driving

Diesel or Hydraulic Hammer

Design & Manufacturing Reference

ACI 543R- 15

Design, Manufactured and Installation of Concrete Piles

SNI 03-2847-2013

Indonesian Concrete Code

Specification of Source Material

Item	Specification	Reference	
Aggregate		ASTM C33 - 2016	Standard Specification Concrete Aggregates
		SNI 8321-2016	Concrete Aggregate Specification
Cement		SNI 15-2049-2004	Portland Cement
Admixture		ASTM C494 - 2016	Standard Specification for Chemical Admixture for Concrete
Concrete	Compressive Strength at 28 Days : 500 kg/cm ² (Cube), 42 MPa (Cylinder)	SNI 2847-2013	Structural Concrete Requirement
PC Strand	KBjP-P7 RB	SNI 1154-2011	Uncoated Seven Wire Stress Relieved Standard for Prestress Concrete (Pc Strand/KBjP-P7)

PC Strand	Grade 270	ASTM A-416	Standard Specification for Uncoated Seven Wire Stress Relieved Strand for Prestressed Concrete
	SWPR7BL	JIS G 3536 : 2014	Uncoated Stress-Relieved steel wires and strands for prestressed concrete
Spiral Wire	SWM-A / SWM-P	JIS G 3532 : 2011	Low Carbon Steel Wires
Reinforce-ment Bar	BJTS 40 For D ≥ 13mm	SNI 2052-2014	Concrete Reinforcement Steel Bar
	BJTP 24 For D < 13mm	SNI 2052-2014	
Join Plate	SS400		Roled Steel for General Structure
Welding	AWS E7016	AWS D1.1 : 2000	Structural Welding Code - Steel

Type of Pile

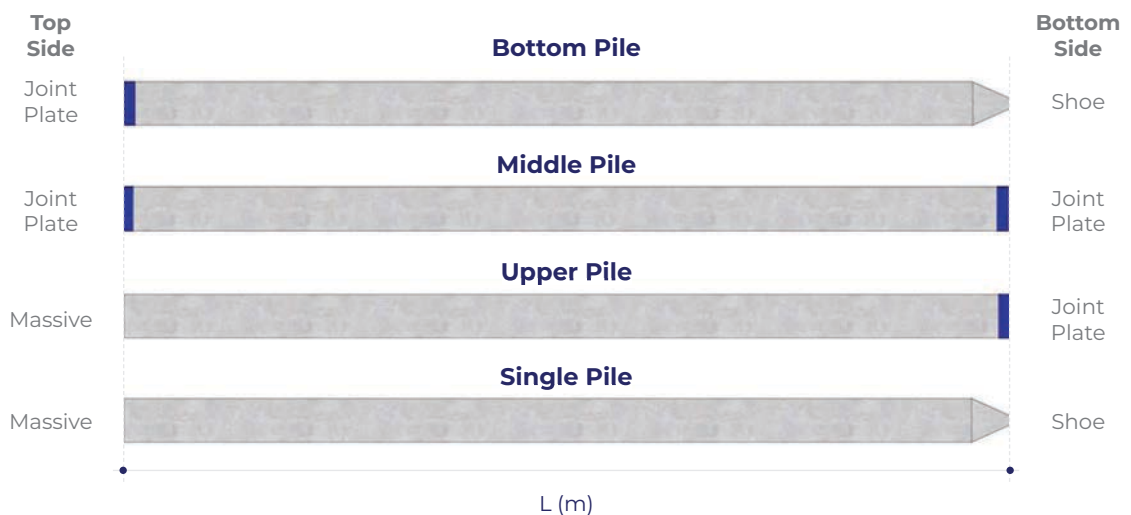

Product Dimension

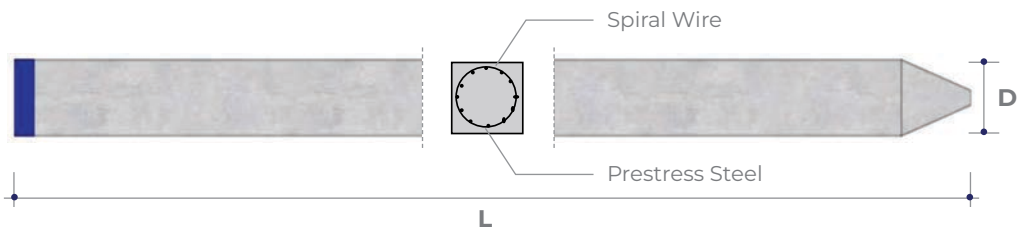

Dimention (D) (cm)	Class	Unit Weight (kg/m)	Bending Moment		Allowable Axial Load (kN)	Length of Pile (L) (m)
			Cracking (kN.m)	Nominal (kN.m)		
25 x 25	A	156	22,06	37,66	798,26	6 - 12
	B		24,52	47,17	780,81	6 - 14
	C		27,07	56,58	764,13	6 - 16



30 x 30	A	225	35,50	56,58	1162,97	6 - 12
	B		38,74	67,86	1145,02	6 - 14
	C		42,46	81,40	1124,43	6 - 16
	D		47,86	101,79	1094,42	6 - 18
35 x 35	A	306	51,19	71,59	1608,09	6 - 12
	B		57,96	95,03	1575,73	6 - 14
	C		64,53	118,76	1544,06	6 - 16
	D		71,00	142,49	1513,36	6 - 18
40 x 40	A	400	76,88	108,56	2098,23	6 - 14
	B		84,73	135,63	2065,28	6 - 16
	C		92,48	162,89	2033,11	6 - 18
	D		114,25	244,28	1941,81	6 - 20
45 x 45	A	506	108,95	152,69	2657,41	6 - 14
	B		117,88	183,19	2624,36	6 - 16
	C		126,51	213,78	2591,90	6 - 18
	D		143,47	274,78	2528,94	6 - 20
50 x 50	A	625	147,79	203,59	3462,92	6 - 14
	B		157,69	237,42	3253,06	6 - 16
	C		167,50	271,45	3220,31	6 - 18
	D		177,11	305,28	3188,04	6 - 20

Joint Detail

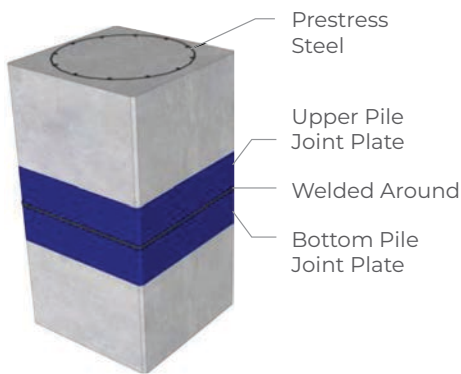

Selection of Pile Drive

Pile Dimension	Type of Diesel Hammer	
	Single Pile	Jointed Pile
25 x 25	K 13	K 13 / K 25
30 x 30	K 13	K 25 / K 35
35 x 35	K 25	K 35
40 x 40	K 25 / K 35	K 35 / K 45
45 x 45	K 35 / K 45	K 45 / KB 45
50 x 50	K 45 / KB 45	K 45 / KB 45 / KB 60





BINA MARGA



Full Slab

Precast Slab Pre-tension product used in the pile slab structure as main road or ramp. Full Slab is easy to install. This product is solution for constructing road on poor soil conditions.

Technical

Prestressing System

Pre-tension

Prestressing System

- Single Crane
- Double Crane
- Launching Gantry
- Launching Truss

Design & Manufacturing Reference

RSNI T-02-2005	Load-Bearing Standards for Bridge Construction
BMS 7	Bridge Design Code
AASHTO - 2002	Standard Specification for Highway Bridge
ACI 318-2011	Building Code Requirement for Structural Concrete
SNI 03-2847-2013	Indonesian Concrete Code
PCI MnI-133	Bridge Design Manual

Specification of Source Material

Item	Specification	Reference
Aggregate		ASTM C33 - 2016 Standard Specification Concrete Aggregates
		SNI 8321-2016 Concrete Aggregate Specification
Cement		SNI 15-2049-2004 Portland's Cement
Admixture		ASTM C494 - 2016 Standard Specification for Chemical Admixture for Concrete
Concrete	Compressive Strength at : 28 Days : 500 kg/cm ² (Cube); 42 MPa (Cylinder)	SNI 2847-2013 Structural Concrete Requirement

PC Strand	KBjP-P7 RB	SNI 1154-2011	Uncoated Seven Wire Stress Relieved Strand for Prestress Concrete (Pc Strand/ KBjP-P7)
	Grade 270	ASTM A-416	Standard Specification for Uncoated Seven_ Wire Stress Relieved Strand for Prestressed Concrete
	SWPR7BL	JIS G 3536 : 2014	Uncoated Stress-Relieved Steel Wires and Strands for Prestressed Concrete
Reinforced Rebar	BjTS 40 For D ≥ 13mm	SNI 2052-2014	Concrete Reinforcement Steel Bar
	BjTP 24 For D < 13mm		

Product Dimension

Type 1A



Type 1B

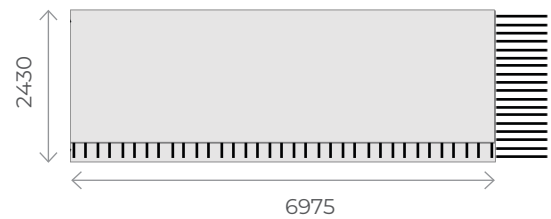

Type 2A



Type 2B

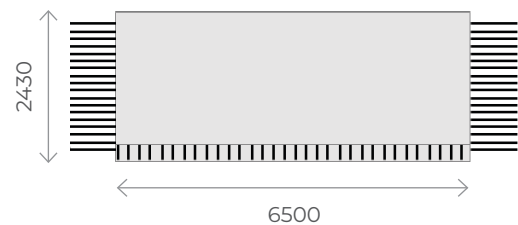

Type 1A & 2A





Type 1B & 2B

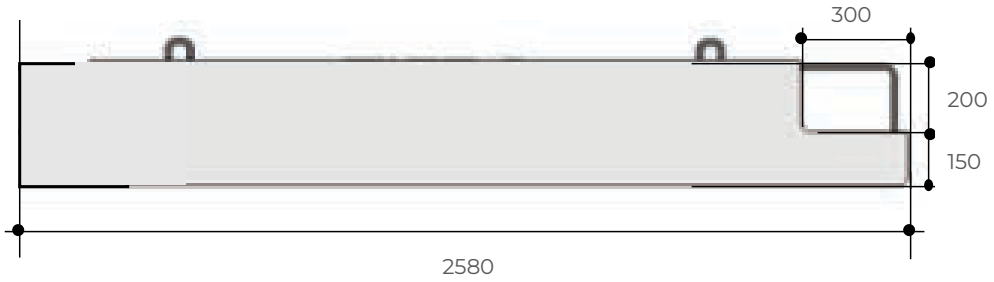

All units in mm

*) Width can be adjusted based on user needs

Connection System

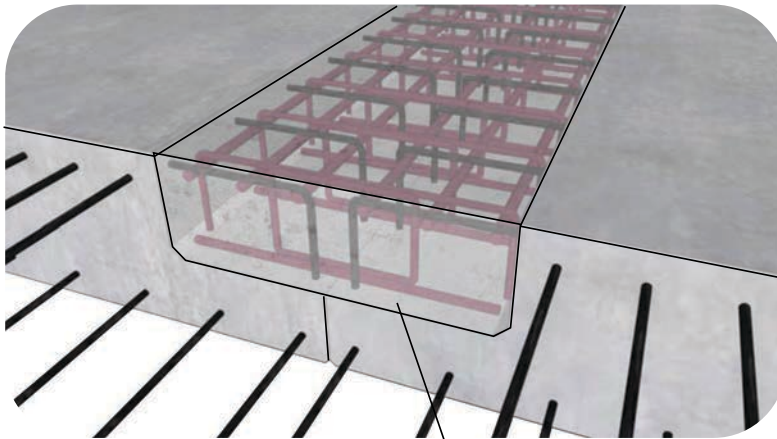

Cast in Situ
Non Shrinkage Concrete
K500 (Cube) or 42 MPa
(Cylinder)





Half Slab

Reinforced slab products that have function as semi-finished slabs (topping is required on the Half Slab surface). Making slab works more practical and time efficient and less supporting tools.

Technical

Prestressing System

Pre Tension

Prestressing System

- Single Crane
- Double Crane
- Launching Gantry
- Launching Truss

Design & Manufacturing Reference

SNI 03-2847-2013	Indonesian Concrete Code
------------------	--------------------------

Specification of Source Material

Item	Specification	Reference
Aggregate	ASTM C33 - 2016	Standard Specification Concrete Aggregates
	SNI 8321-2016	Concrete Aggregate Specification
Cement	SNI 15-2049-2004	Portland's Cement
Admixture	ASTM C494 - 2016	Standard Specification for Chemical Admixture for Concrete
Concrete	Compressive Strength at : 28 Days : 350 kg/cm ² (Cube) ; 30 MPa (Cylinder)	SNI 2847-2013 Structural Concrete Requirement
Reinforced Rebar	BJTS 40 For D ≥ 13mm	SNI 2052-2014 Concrete Reinforcement Steel Bar
	BJTP 24 For D < 13mm	

Product Dimension

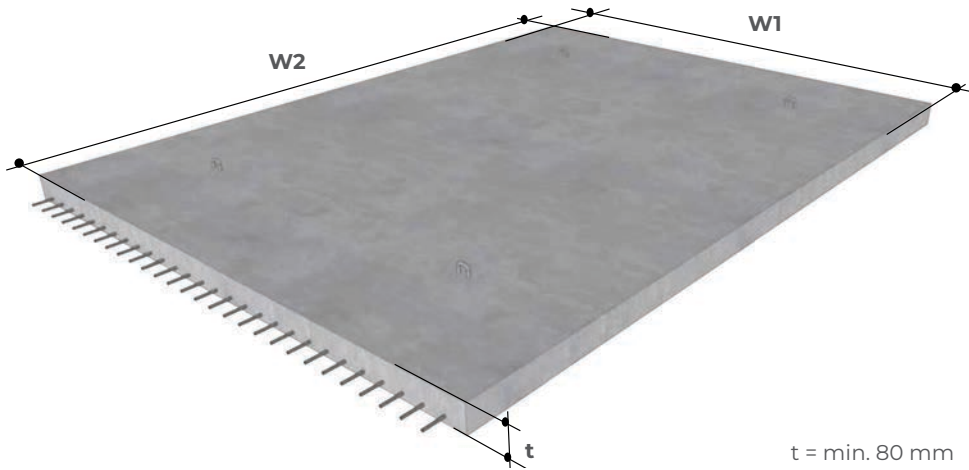

$W1$ & $W2$ dimensions determined based on floor plan of the building,
and lifting equipment available at site

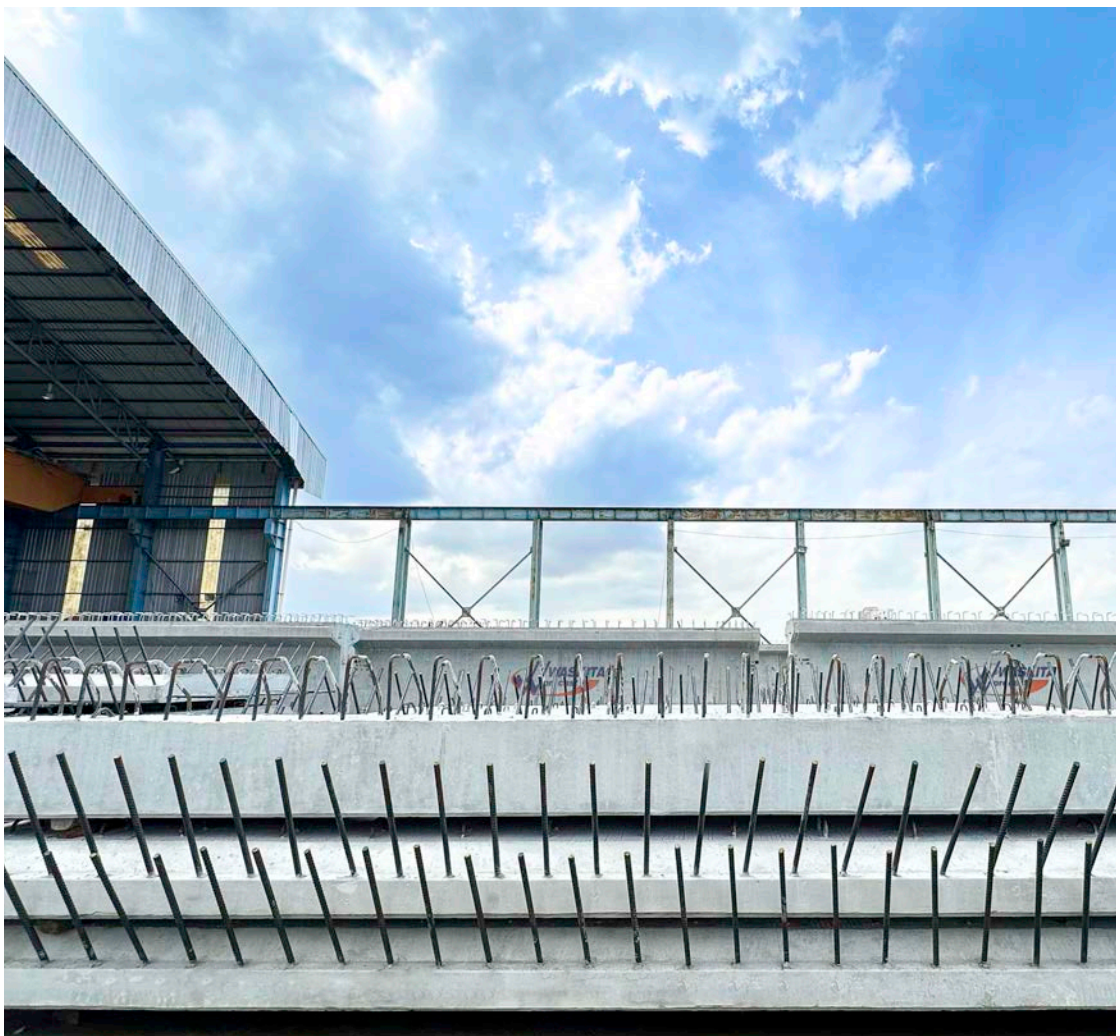



Voided Slab

Precast Concrete Prestensions that have function as short span bridges (span max 17 m). Void in the slab makes bridge structure lighter and more efficient.

Technical

Prestressing System

Pre Tension

Erection System

- Launching Gantry
- Launching Truss
- Double Crane
- Single Crane (Max. 15 m)

Design & Manufacturing Reference

RSNI T-02-2005	Standard Loading for Bridges
BMS 7	Bridge Design Code
AASHTO-2002	Standard Specification for Highway Bridge
ACI 318-2011	Building Code Requirement for Structural Concrete
SNI 03-2847-2013	Indonesian Concrete Code
PCI MnI -133	Bridge Design Manual

Specification of Source Material

Item	Specification	Reference
Aggregate	ASTM C33 - 2016	Standard Specification Concrete Aggregates
	SNI 8321-2016	Concrete Aggregate Specification
Cement	SNI 15-2049-2004	Portland's Cement
Admixture	ASTM C494 - 2016	Standard Specification for Chemical Admixture for Concrete
Concrete	Compressive Strength at : 28 Days : 500 kg/cm ² (Cube); 42 MPa (Cylinder)	SNI 2847-2013 Structural Concrete Requirement

PC Strand	KBjP-P7 RB	SNI 1154-2011	Uncoated Seven Wire Stress Relieved Strand for Prestress Concrete (Pc Strand/ KBjP-P7)
	Grade 270	ASTM A-416	Standard Specification for Uncoated Seven_ Wire Stress Relieved Strand for Prestressed Concrete
	SWPR7BL	JIS G 3536 : 2014	Uncoated Stress-Relieved Steel Wires and Strands for Prestressed Concrete
Reinforced Rebar	BjTS 40 For D ≥ 13mm BjTP 24 For D < 13mm	SNI 2052-2014	Concrete Reinforcement Steel Bar

Product Dimension

Type 1

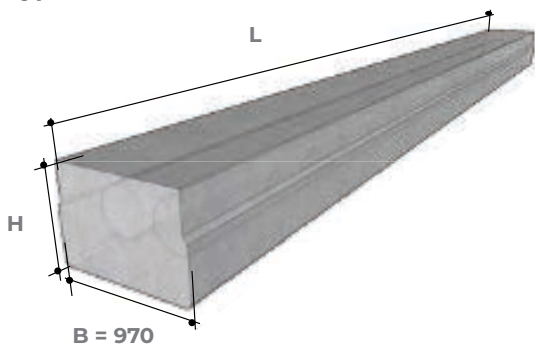

Type 2

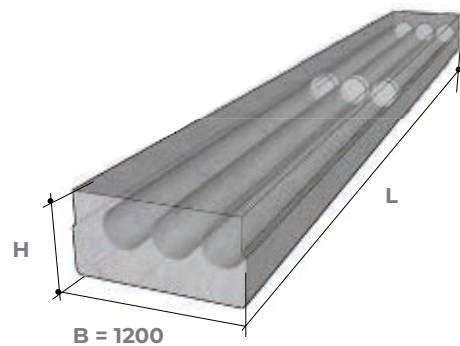

All units in mm

Height-H (cm)	Span-L (m)	
	K-500	K-800
H-57	5 - 14	15
H-62	5 - 15	16
H-66	5 - 16	17

Height-H (cm)	Span-L (m)	
	K-500	K-800
H-52,5	5 - 11	12
H-62,5	5 - 14	15 - 17

Typical Cross Section

Type 1

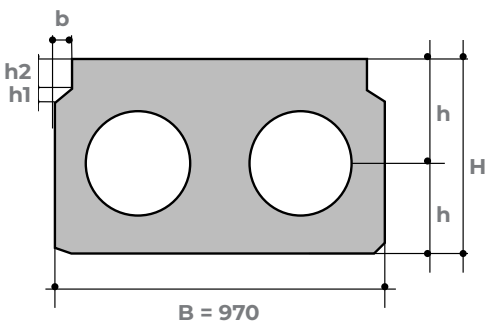

Type 2

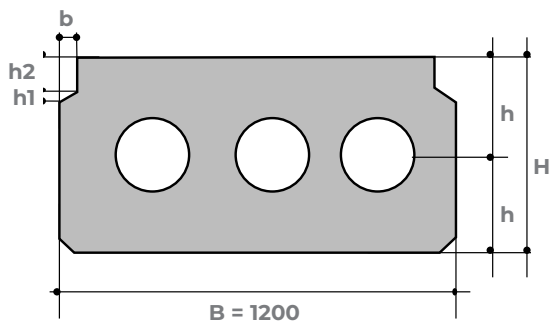

All units in mm



Notation	Unit (mm)	H (cm)				
		Type 1			Type 2	
		570	620	660	525	625
B	mm	970	970	970	1200	1200
h	mm	285	310	330	262,5	312,5
h1	mm	25	25	25	25	25
h2	mm	75	100	120	75	100
b	mm	50	50	50	50	50
D	mm	250	300	350	250	300





SPRigWP

Waskita Precast Rigid Pavement System

SPRigWP is an innovative product featuring a continuous reinforced concrete pavement (CRCP) system with unbonded prestressing, designed in the form of precast modular panels. The arrangement of these SPRigWP panels uses a specialized joint system called the dowel activator.

Technical

Designed for Class 1 Road (Max. Axle Load : 10 Ton) & Highway

Advantage

1. Easier to replace because of single panel prestressing system
2. Easy to install

Design & Manufacturing Reference

No. 038/TBM/1997	Geometric Planning Procedures for Intercity Ro
No. 007/BM/2009	Geometry of Freeways for Toll Roads
SE No : 15/SE/M/2015	Guidelines for Implementing Precast-Prestressed Cement Concrete Pavement
SNI 03-2847-2013	Indonesia Concrete Code

Specification of Source Material

Item	Specification	Reference
Aggregate	ASTM C33 - 2016	Standard Specification Concrete Aggregates
	SNI 8321-2016	Concrete Aggregate Specification
Cement	SNI 15-2049-2004	Portland's Cement
Admixture	ASTM C494 - 2016	Standard Specification for Chemical Admixture for Concrete



Concrete	Compressive Strength at : 28 Days : 500 kg/cm ² (Cube); 42 MPa (Cylinder)	SNI 2847-2013	Structural Concrete Requirement
PC Strand	KBjP-P7 RB	SNI 1154-2011	Uncoated Seven Wire Stress Relieved Standard for Prestress Concrete (Pc Strand/ KBjP-P7)
	Grade 270	ASTM A-416	Standard Specification for Uncoated Seven_ Wire Stress Relieved Strand for Prestressed Concrete
	SWPR7BL	JIS G 3536 : 2014	Uncoated Stress-Relieved Steel Wires and Strands for Prestressed Concrete
Reinforced Rebar	BjTS 40 For D ≥ 13mm	SNI 2052-2014	Concrete Reinforcement Steel Bar
	BjTP 24 For D < 13mm		

Specification of Source Material

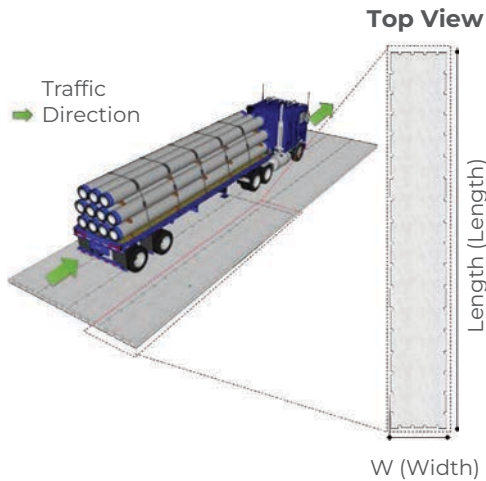

Side View



W (mm)	L (mm)
1800	12000
3600	12000

Available in 2 thicknes :
180 mm & 200 mm





Movable Concrete Barrier (MCB)

Precast Concrete Barrier which has many functions, it can be used as a road median/road lane separator, and work area fence on the project site. Thanks for its small form, makes it easy to move and install. This product is knock down, so it can be assembled and disassembled according to user needs.

Technical

Type of Connection

Shear Key

Design & Manufacturing Reference

SNI 03-2847-2013	Indonesian Concrete Code
------------------	--------------------------

Specification of Source Material

Item	Specification	Reference
Aggregate	ASTM C33 - 2016	Standard Specification Concrete Aggregates
	SNI 8321-2016	Concrete Aggregate Specification
Cement	SNI 15-2049-2004	Portland's Cement
Admixture	ASTM C494 - 2016	Standard Specification for Chemical Admixture for Concrete
Concrete	Compressive Strength at : 28 Days : 350 kg/cm ² (Cube) ; 30 MPa (Cylinder)	SNI 2847-2013 Structural Concrete Requirement
Reinforced Rebar	BJTS 40 For D ≥ 13mm BJTP 24 For D < 13mm	SNI 2052-2014 Concrete Reinforcement Steel Bar

Connection System

Type 1

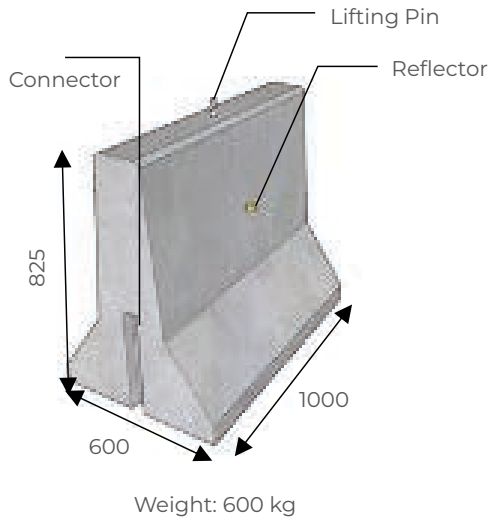

Type 2

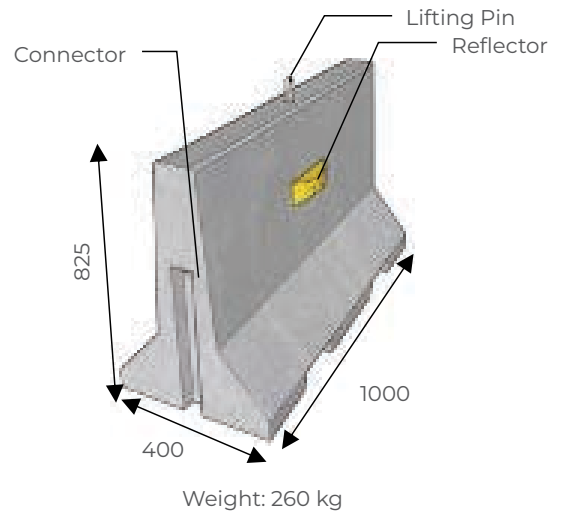

Type 3

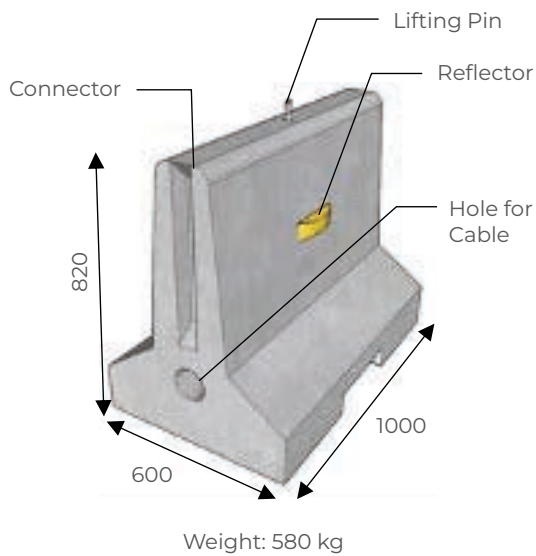

Dimension can be modified based on user needs.





Concrete Sleeper for Railway (BJR)

Technical

Type of Connection

Shear Key

Design & Manufacturing Reference

SK.516/KA.604/DRJD/2002	Technical instructions for the use of concrete sleepers
HK.207/SK.61/DJKA/5/13	Precast Concrete Standards for Railway Infrastructure
AREMA Ch. 30	Concrete Ties

Specification of Source Material

Item	Specification	Reference
Aggregate		ASTM C33 - 2016 Standard Specification Concrete Aggregates
		SNI 8321-2016 Concrete Aggregate Specification
Cement		SNI 15-2049-2004 Portland's Cement
Admixture		ASTM C494 - 2016 Standard Specification for Chemical Admixture for Concrete
Concrete	Compressive Strength at : 28 Days : 350 kg/cm ² (Cube); 42 MPa (Cylinder)	SNI 2847-2013 Structural Concrete Requirement
PC Wire	SBPDL 1275/1420	JIS G 3536 : 2008 Steel wires and strands for prestressed concrete
	KBjP-R	SNI 1155 : 2011 Uncoated Steel Wire for Prestress Concrete (KBjP/Pc Wire)
PC Bar	SWPD-1	JIS G 3137 : 2008 Small diameter steel bars for prestressed concrete
	KBjP-Q RI	SNI 7701 : 2011 Quench Tempered Steel Wire for Prestressed Concrete Construction (PC Bar/KBjP-Q)

Product Dimension

BJR-1067

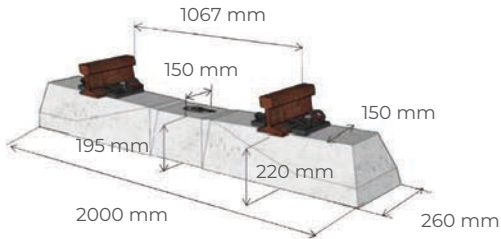

BJR-1435

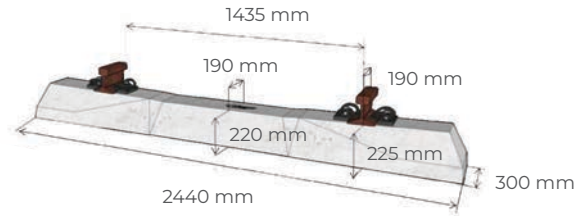

Jenis	Sleeper Length (mm)	Depth (mm)		Width at Rail Seat (mm)		Width at Center (mm)	
		At Rail Seat	At Center	Upper	Bottom	Upper	Bottom
BJR-1067	2000	220	195	150	260	150	245
BJR-1435	2440	225	200	190	300	190	285

Technical Specification

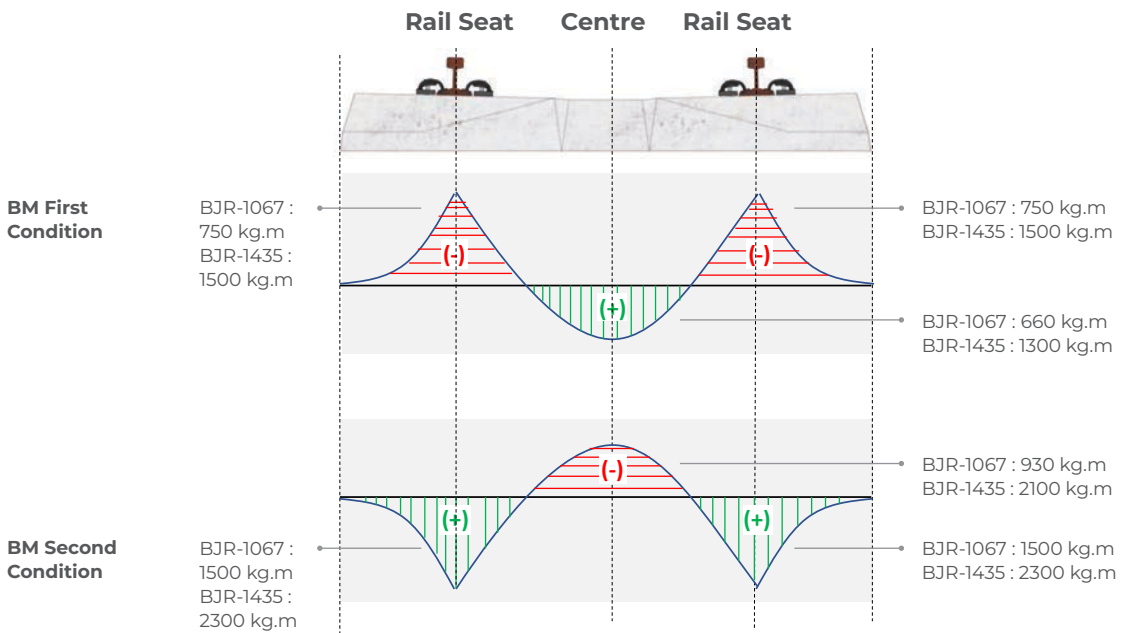

Jenis	Track Gauge (mm)	Design Axle Load (ton)	Train Speed (km/h)	Sleeper Weight (kg)	Moment at rail seat		Moments at Centre	
					Positive (+)	Negative (-)	Positive (+)	Negative (-)
BJR-1067	1067	18	120	203	1500	750	660	930
BJR-1435	1435	25	160	316	2300	1500	1300	2100



Electric Poles

Prestress Concrete Poles for Electrical Distribution Line with concrete strength at 28 days : 500 kg/cm²

Design & Manufacturing Reference

SPLN D3.019-2 : 2013	Electric Pole Specification Part 2 : Prestressed Concrete Poles
SNI 03-2847-2022	Indonesia Standard Code for Structural Concrete

Specification of Source Material

Item	Specification	Reference
Aggregate		ASTM C33 - 2016 Standard Specification Concrete Aggregates
		SNI 8321-2016 Concrete Aggregate Specification
Cement		SNI 15-2049-2004 Portland's Cement
Admixture		ASTM C494 - 2016 Standard Specification for Chemical Admixture for Concrete
Concrete	Compressive Strength at 28 Days : 500 kg/cm ² (Cube); 50 MPa (Cylinder)	SNI 2847-2013 Structural Concrete Requirement
PC Wire	SBPDL 1275/1420	JIS G 3536 : 2008 Steel Wires and Strands for Prestressed Concrete
	KBJP-R	SNI 1155 : 2011 Uncoated Steel Wire for Prestress Concrete (KBJP/Pc Wire)
PC Bar	SWPD-1	JIS G 3137 : 2008 Small Diameter Steel Bar for Prestressed Concrete
	KBJP-Q RI	SNI 7701 : 2011 Quench Steel Bar for Precast Concrete (Pc Bar/KBJP-Q)
Spiral Wire	SWM-A / SWM-P	JIS G 3532 : 2011 Low Carbon Steel Wires
	BJTS 40 For D >10mm	SNI 2052-2014 Concrete Reinforcement Steel Bar
Reinforcement Bar	BjTP 24 For D ≤ 10mm Maximum resistance : 5x10 ⁻³ ohm/m	(SPLN D3.019-2 : 2013) Electric Pole Specification Part 2 : Prestressed Concrete Poles
Welding	AWS E7016	AWS D11 : 2000 Structural Welding Code - Steel

Product Dimension

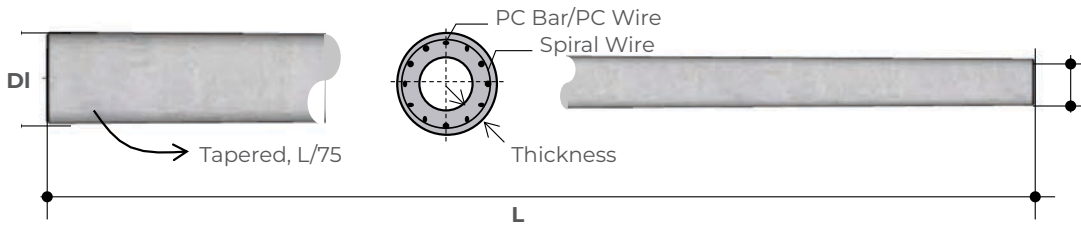

Type	Length L(m)	Working load (daN)	Outer Nominal Diameter (mm)		Product Thickness (mm)	
			Upper (Du)	Bottom (DI)	Upper	Bottom
9/100 (157)	9	100	157	277	40	55
9/200 (157)	9	200	157	277	40	55
9/350 (190)	9	350	190	310	45	60
11/200 (190)	11	200	190	337	45	70
11/350 (190)	11	350	190	337	45	70
11/500 (190)	11	500	190	337	45	70
12/200 (190)	12	200	190	350	45	75
12/350 (190)	12	350	190	350	45	75
12/500 (190)	12	500	190	350	45	75
13/350 (190)	13	350	190	363	45	80
13/500 (190)	13	500	190	363	45	80
14/350 (190)	14	350	190	377	45	90
14/500 (190)	14	500	190	377	45	90

Product Dimension

According to SPLN D3.019-2: 2013

Normal Embedded

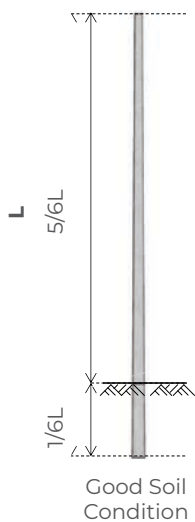

Using bamboo or crucuk wood reinforcement





IRRIGATION

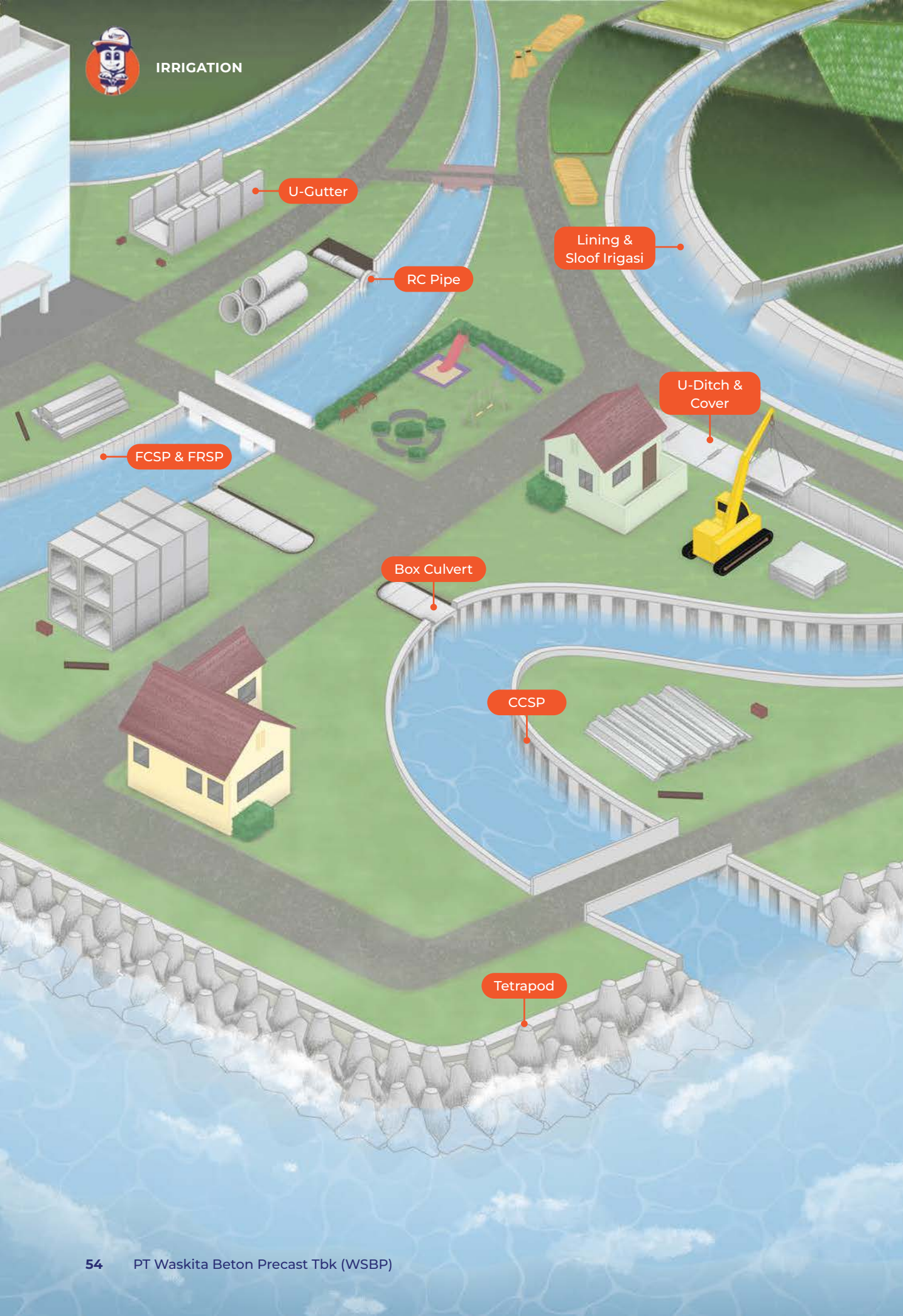

U-Gutter

RC Pipe

Lining & Sloof Irigasi

U-Ditch & Cover

FCSP & FRSP

Box Culvert

CCSP

Tetrapod

Irrigation

CCSP

FCSP & FRSP

Tetrapod

RC Pipe

U-Gutter

Lining

Sloof Irigrasi

U-Ditch & cover

Box Culvert

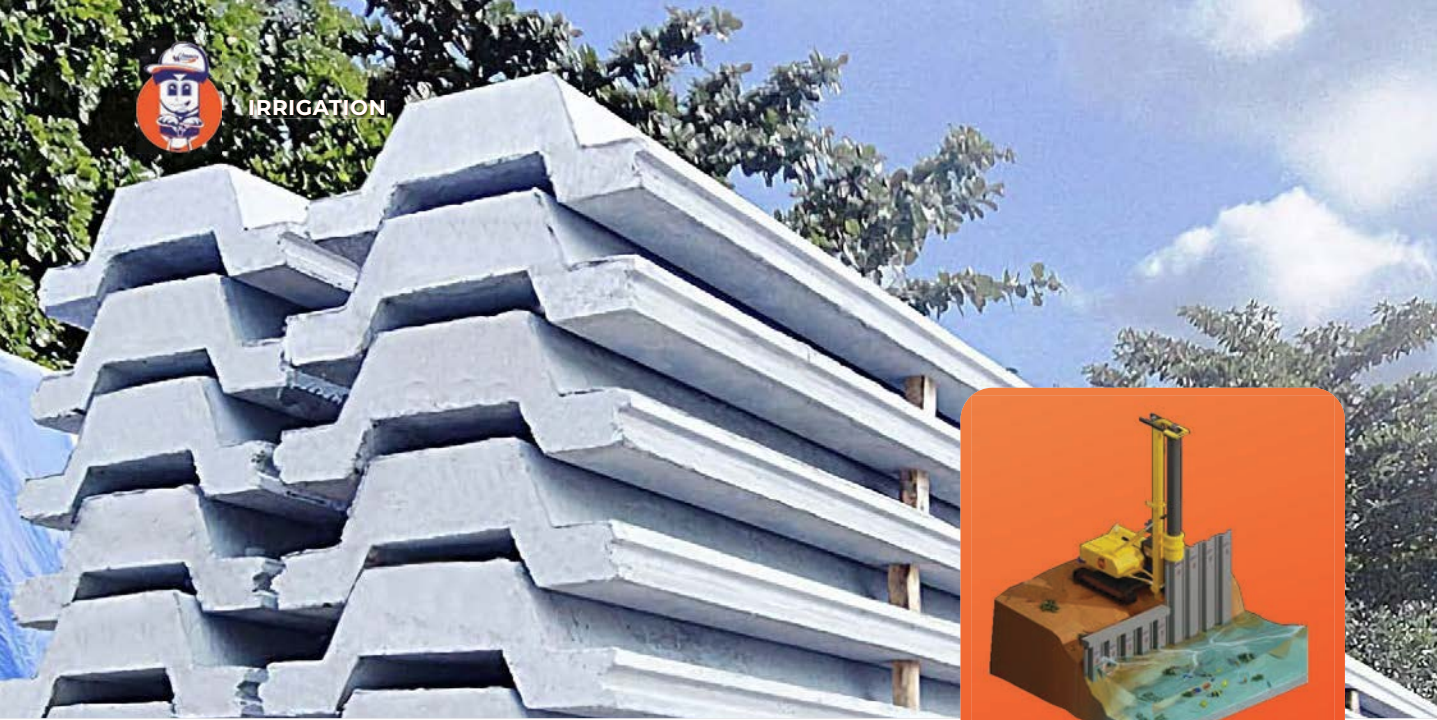

CCSP

Sheet pile which has corrugated geometry causes sheet pile to have a large bending moment capacity. Sheet pile is suitable for use as a retaining wall with a deep embedment depth. Drive efficiently cause this sheet pile have 1 m width.

Technical

Type of Sheet Pile

CCSP (Corrugated Concrete Sheet Pile)
Prestressed

Method of Driving

- Vibro or Diesel Hammer (Typical)
- Vibro Hammer and Water Jet (Typical)

System of Joint Between Sheet Pile

- Male-Female (Typical)
- Water Tight Joint (Special Order)

Design & Manufacturing Reference

IS A5326 - 1988	Prestressed Concrete Sheet Piles
SNI 03-2847-2013	Indonesian Concrete Code
JIS A5373 - 2010	Precast Prestressed Concrete Product

Specification of Source Material

Item	Specification	Reference	
Aggregate		ASTM C33 - 2016	Standard Specification Concrete Aggregates
		SNI 8321-2016	Concrete Aggregate Specification
Cement		SNI 15-2049-2004	Portland's Cement
Admixture		ASTM C494 - 2016	Standard Specification for Chemical Admixture for Concrete
Concrete	Compressive Strength at : 28 Days : 700 kg/cm ² (Cube); 55 MPa (Cylinder)	SNI 2847-2013	Structural Concrete Requirement

PC Strand	KBJP-P7 RB	SNI 1154-2011	Uncoated Seven Wire Stress Relieved Strand for Prestress Concrete (Pc Strand/ KBJP-P7)
	Grade 270	ASTM A-416	Standard Specification for Uncoated Seven_ Wire Stress Relieved Strand for Prestressed Concrete
	SWPR7BL	JIS G 3536 : 2014	Uncoated Stress-Relieved Steel Wires and Strands for Prestressed Concrete
Reinforced Rebar	BjTS 40 For D ≥ 13mm	SNI 2052-2014	Concrete Reinforcement Steel Bar
	BjTP 24 For D < 13mm		

Product Dimension

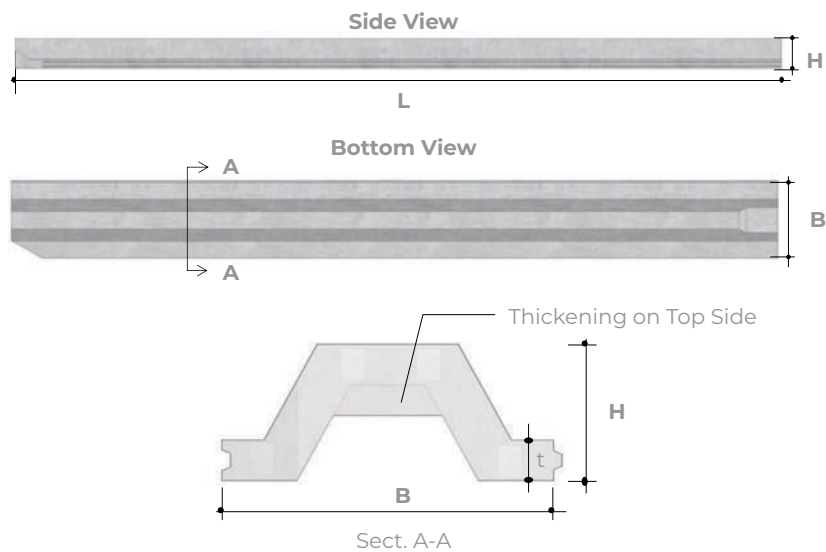

Dimension (D) (cm)	Height H (mm)	Thickness t (mm)	Width W (mm)	Cross Section (cm ²)	Moment of Inertia (cm ⁴)	Unit Weight (kg/m)	Crack Moment (kN.m)	Length L (m)
W-325 A 1000	325	110	996	1,315	134,261	329	120	8 - 15
W-325 B 1000							130	8 - 16
W-350 A 1000	350	120	996	1,468	139,432	368	160	9 - 17
W-350 B 1000							170	10 - 18
W-400 A 1000	400	120	996	1,598	248,685	400	200	10 - 18
W-400 B 1000							230	11 - 20
W-450 A 1000	450	120	996	1,835	353,354	459	270	11 - 20
W-450 B 1000							310	12 - 21
W-500 A 1000	500	120	996	1,818	462,362	455	350	12 - 17
W-500 B 1000							400	13 - 18
W-600 A 1000	600	120	996	2,078	765,907	525	500	14 - 25
W-600 B 1000							590	15 - 27

Notes:

- There are no differences in sectional properties.
- Dimensions outside the table must be based on an agreement between the concerned parties.



Sheet Pile Installation Example

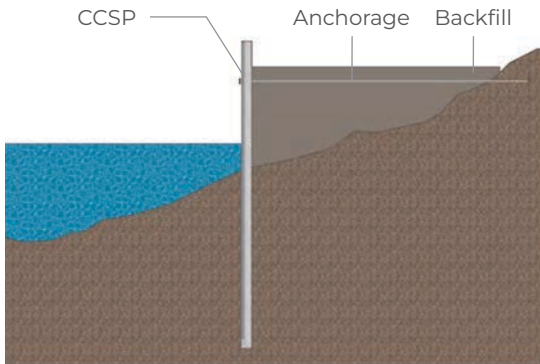

Join System

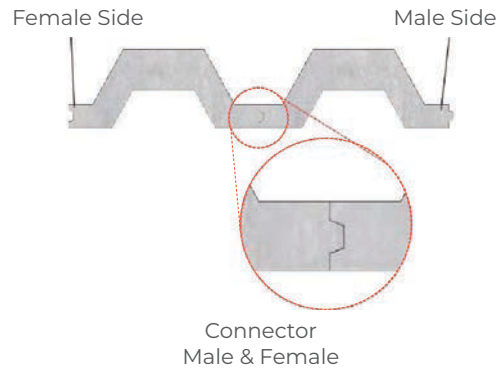

Water Jet System (Special Order)

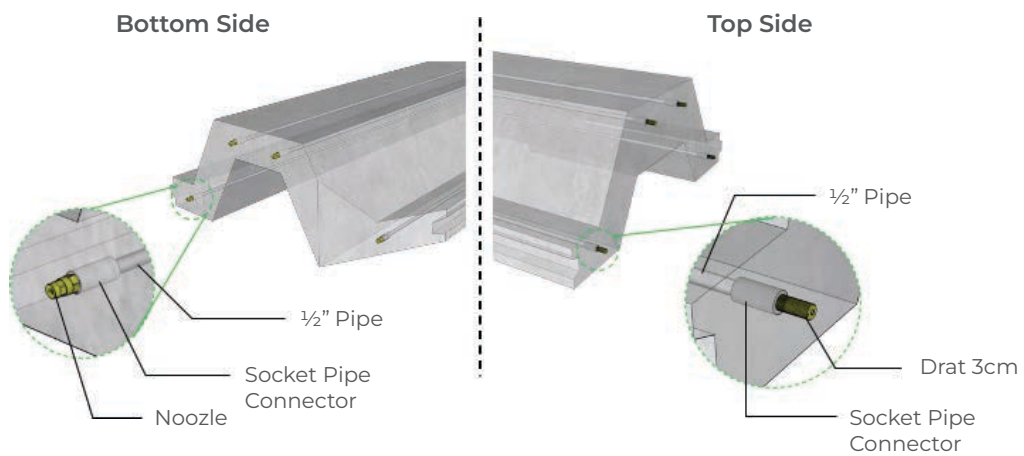

Note : This system recommended to used in granuler soil / sand

Guide For Choosing Vibro Hammer

Determining Driving Classification

Soil Type	Normal Extracting	Normal Driving	Heavy Driving
Fine	1 - 6	7 - 17	18 - 35
Medium	3 - 8	9 - 22	23 - 42
Coarse	5 - 10	11 - 27	28 - 48

Step-1 If using Cone Resistance (CPT) Value

Soil Type	Normal Extracting	Normal Driving	Heavy Driving
Fine	3 - 18	19 - 44	45 - 80
Medium	5 - 16	17 - 46	47 - 80
Coarse	5 - 14	15 - 40	41 - 65

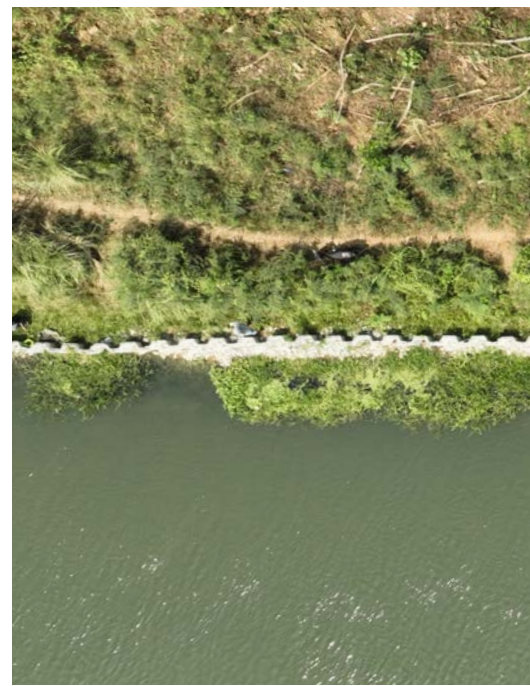

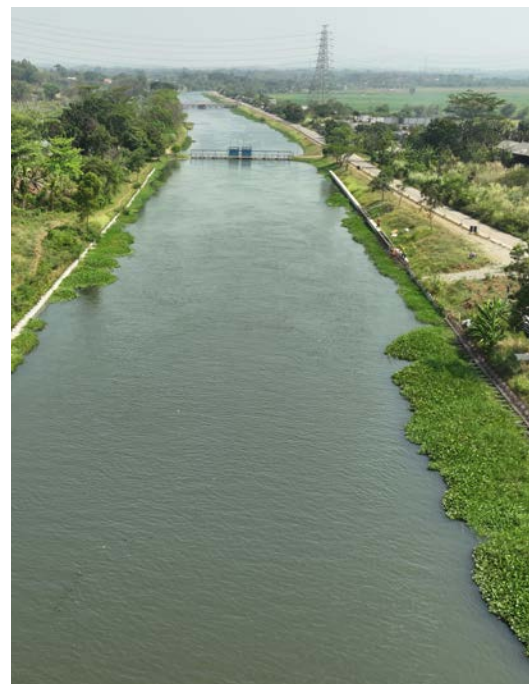



FCSP & FRSP

Sheet pile which has a flat geometry, so that the bending moment is not too big compared to CCSP, but has a lighter weight which makes the shipping process easier. This sheet pile is suitable for shallow embedment depth retaining wall

Technical

Type of Sheet Pile

- FCSP (Flat Concrete Sheet Pile) Prestressed
- FRSP (Flat Reinforced Sheet Pile) Non-Prestressed

Method of Driving

- Vibro or Diesel Hammer (Standard)
- Vibro Hammer and Water Jet (Special Order)

System of Joint Between Sheet Pile

- Male-Female (Standard)
- Water Tight Joint (Special Order)

Design & Manufacturing Reference

JIS A5326 - 1988	Prestressed Concrete Sheet Piles
SNI 03-2847-2013	Indonesian Concrete Code
JIS A5373 - 2010	Precast Prestressed Concrete Product
JIS A5325 - 1990	Reinforced Concrete Sheet Pile

Specification of Source Material

Item	Specification	Reference
Aggregate	ASTM C33 - 2016	Standard Specification Concrete Aggregates
	SNI 8321-2016	Concrete Aggregate Specification
Cement	SNI 15-2049-2004	Portland's Cement
Admixture	ASTM C494 - 2016	Standard Specification for Chemical Admixture for Concrete

Concrete	FCSP Compressive Strength at : 28 Days : 700 kg/cm ² (Cube), 55 MPa (Cylinder)	SNI 2847-2013	Structural Concrete Requirement
	FRSP Compressive Strength at : 28 Days : 350 kg/cm ² or 500 kg/cm ² (Cube) , 30 MPa or 42 MPa (Cylinder)		
PC Strand	KBJP-P7 RB	SNI 1154-2011	Uncoated Seven Wire Stress Relieved Strand for Prestress Concrete (Pc Strand/ KBJP-P7)
	Grade 270	ASTM A-416	Standard Specification for Uncoated Seven_ Wire Stress Relieved Strand for Prestressed Concrete
	SWPR7BL	JIS G 3536 : 2014	Uncoated Stress-Relieved Steel Wires and Strands for Prestressed Concrete
PC Wire	SBPDL 1275/1420	SNI 2847-2013	Steel Wires and Strands for Prestressed Concrete)
	KBJP-R	SNI 1155 : 2011	Uncoated Steel Wire for Prestress Concrete (KBJP/Pc Wire)
PC Bar	SWPD-1	JIS G 3137 : 2008	Small Diameter Steel Bars For Prestressed Concrete
	KBJP-Q RI	SNI 7701 : 2011	Quench Steel Bar for Precast Concrete (Pc Bar/KBJP-Q)
Reinforced Rebar	BjTS 40 For D ≥ 13mm	SNI 2052-2014	Concrete Reinforcement Steel Bar
	BjTP 24 For D < 13mm		

Product Dimension



FCSP

Type	Width W (mm)	Thickness t (mm)	Unit Weight (kg/m)	Bending Moment		Length L (mm)
				Crack (Ton.m)	Ultimate (Ton.m)	
FCSP-220 A 500	500	220	280	3.32	5.39	6 - 14
B				3.70	6.74	
C				4.05	8.09	
D				4.39	9.44	
E				4.71	10.79	
F				5.22	10.96	6 - 14
G				5.97	13.7	



FCSP-320 A 500	500	320	400	6.05	7.85	6 - 14
B				6.65	9.81	
C				7.24	11.77	
D				7.81	13.73	
E				8.37	15.59	
F				8.91	17.65	
G				9.43	19.61	
H				9.94	21.57	
I				10.43	23.54	
J				10.91	25.52	
K				11.37	27.46	
L				11.81	29.42	
M				12.24	31.38	
N				13.38	31.88	

FRSP

Type	Width W (mm)	Thickness t (mm)	Unit Weight (kg/m)	Crack Moment (Ton.m)	Length (m)
Concrete Compressive Strength: 350 kg/cm ² (Cube); 30 MPa (Cylinder)					
FRSP - 220 A 500	500	220	280	1.45	4 - 10
FRSP - 320 A 500	500	320	400	3.22	4 - 12
Concrete Compressive Strength: 500 kg/cm ² (Cube); 42 MPa (Cylinder)					
FRSP - 220 B 500	500	220	280	1.70	4 - 10
FRSP - 320 B 500	500	320	400	3.61	4 - 12

Nomogram For Choosing Type of Diesel Hammer

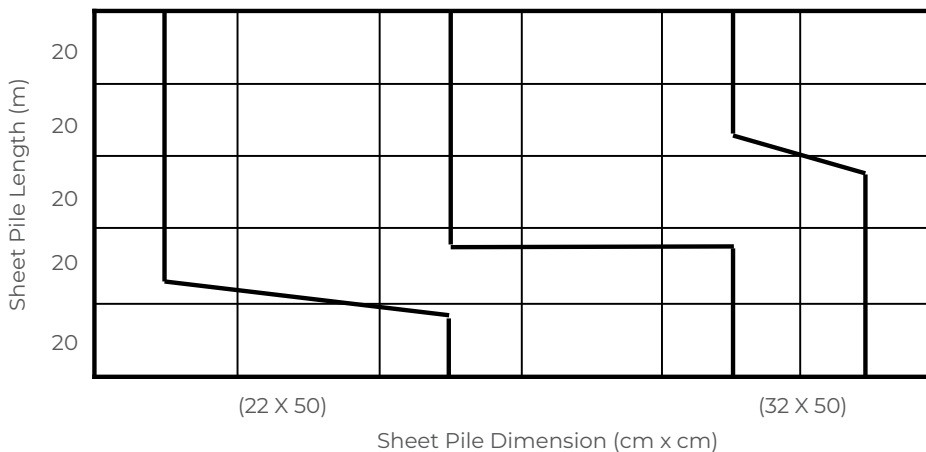



Tetrapod

Precast concrete that functions as a breakwater and can be used on jetty structure. Has an stability index (Kd) between 6-8

Technical

Stability Index (Kd)

6-8

Design & Manufacturing Reference

SNI 03-2847-2013

Indonesian Concrete Code

Specification of Source Material

Item	Specification	Reference
Aggregate	ASTM C33 - 2016	Standard Specification Concrete Aggregates
	SNI 8321-2016	Concrete Aggregate Specification
Cement	SNI 15-2049-2004	Portland's Cement
Admixture	ASTM C494 - 2016	Standard Specification for Chemical Admixture for Concrete
Concrete	Compressive Strength at : 28 Days : 300 kg/cm ² (Cube); 25 MPa (Cylinder)	SNI 2847-2013 Structural Concrete Requirement
Spiral Wire	SWM-P	JIS G 3532 : 2011 Low Carbon Steel Wires
Reinforced Rebar	BjTS 40 For D ≥ 13mm	SNI 2052-2014 Concrete Reinforcement Steel Bar
	BjTP 24 For D < 13mm	



Product Dimension

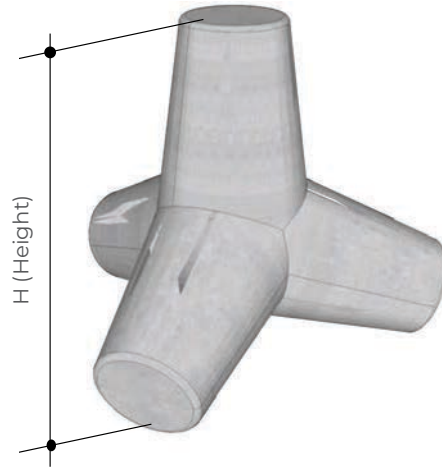

Type	Volume (m ³)	Height (H) (mm)	Weight (ton)
WBP-Tetra 0.25	0.1	710	0.25
WBP-Tetra 0.5	0.2	900	0.5
WBP-Tetra 1	0.4	1,130	1
WBP-Tetra 2	0.8	1,420	2
WBP-Tetra 4	1.6	1,790	4
WBP-Tetra 8	3.2	2,260	8
WBP-Tetra 12.5	5	2,620	12.5





RC Pipe

Precast channels that have a circular cross section, are generally used as buried water tunnel.

Technical

Compressive Strength at 28 Days:

Class 1	350 kg/cm ² (Cube); 30 MPa (Cylinder)
Class 2	600 kg/cm ² (Cube); 50 MPa (Cylinder)
Type 2K	350 kg/cm ² (Cube); 30 MPa (Cylinder)
Type 4K	600 kg/cm ² (Cube); 50 MPa (Cylinder)
Type 6K	600 kg/cm ² (Cube); 50 MPa (Cylinder)

Class 1, Class 2 for External pressure
Class 2K, Class 4K, Class 6K for Internal Pressure

Type of Production :
Dry cast or Wet cast with high frequency vibration

Design & Manufacturing Reference

JIS A 5372-2004	Precast Reinforced Concrete Products
JIS G 3532-2004	Low Carbon Steel Wires
ASCE 15-98	Standard Practice for Direct Design of Buried Precast Concrete Pipe Using Standard (SIDD)
Structural Mechanics of Buried Pipes, CRC Press	
JIS K6353	Rubber Goods for Water Work

Specification of Source Material

Item	Specification	Reference
Aggregate	ASTM C33 - 2016	Standard Specification Concrete Aggregates
	SNI 8321-2016	Concrete Aggregate Specification

Cement		SNI 15-2049-2004	Portland's Cement
Admixture		ASTM C494 - 2016	Standard Specification for Chemical Admixture for Concrete
Concrete	Compressive Strength at : 28 Days : 350 kg/cm ² or 600 kg/cm ² (Cube); 30 MPa or 50 MPa (Cylinder)	SNI 2847-2013	Structural Concrete Requirement
Spiral Wire	SWM-P	JIS G 3532 : 2011	Low Carbon Steel Wires
Rubber Gasket	Class 2 No. 3B, Class 2 No. 2B	JIS K 6353 - 2011	Rubber Goods for Water Work

Product Dimension

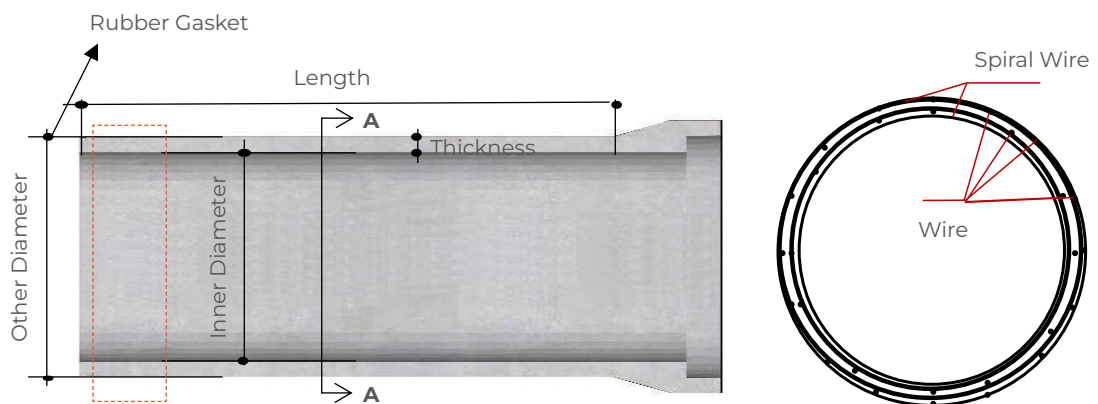

Product Type	Class	Inner Diameter (mm)	Outer Diameter (mm)	Length (mm)	Thickness (mm)	Weight (kg)	Crack Load (kN/m)	Ultimate Load (kN/m)	Hydrostatic Pressure (MPa)
Ø 150	Class-1	150	216	2500	33	125	9	17	-
	Class-2						14	26	-
	2K						16.7	33.4	0.2
	4K						17.7	35.4	0.4
	6K						19.7	39.3	0.6
Ø 200	Class-1	200	270	2500	35	171	10	18	-
	Class-2						16	28	-
	2K						-	-	0.2
	4K						19.7	39.3	0.4
	6K						21.6	43.2	0.6
Ø 250	Class-1	250	326	2500	38	228	12	19	-
	Class-2						18	30	-
	2K						-	-	0.2
	4K						20.7	41.3	0.4
	6K						23.6	47.1	0.6
Ø 300	Class-1	300	400	2500	50	360	13	20	-
	Class-2						21	38	-
	2K						17.7	35.4	0.2
	4K						21.6	43.2	0.4
	6K						25.6	51.1	0.6



IRRIGATION

Ø 350	Class-1						14	22	-
	Class-2						23	42	-
	2K	350	456	2500	53	441	19.7	39.3	0.2
	4K						23.6	47.1	0.4
	6K						27.5	55	0.6
Ø 400	Class-1						15	24	-
	Class-2						24	44	-
	2K	400	516	2500	58	548	21.6	43.2	0.2
	4K						25.6	51.1	0.4
	6K						29.5	58.9	0.6
Ø 450	Class-1						16	26	-
	Class-2						26	49	-
	2K	450	576	2500	63	670	23.6	47.1	0.2
	4K						27.5	55	0.4
	6K						31.4	62.8	0.6
Ø 500	Class-1						17	28	-
	Class-2						28	55	-
	2K	500	638	2500	69	815	25.6	51.1	0.2
	4K						29.5	58.9	0.4
							33.4	66.8	0.6
Ø 600	Class-1						19	32	-
	Class-2						30	60	-
	2K	600	752	2500	76	1083	29.5	58.9	0.2
	4K						32.4	64.8	0.4
	6K						36.3	72.6	0.6
Ø 700	Class-1						23	37	-
	Class-2						33	66	-
	2K	700	866	2500	83	1347	32.4	64.8	0.2
	4K						36.3	72.6	0.4
	6K						40.3	80.5	0.6
Ø 800	Class-1						26	45	-
	Class-2						36	72	-
	2K	800	982	2500	91	1687	35.4	70.7	0.2
	4K						39.3	78.5	0.4
	6K						44.2	88.3	0.6
Ø 900	Class-1						27	51	-
	Class-2						39	78	-
	2K	900	1100	2500	100	2094	38.3	76.6	0.2
	4K						47.1	94.2	0.4
	6K						-	-	0.6
Ø 1000	Class-1						29	60	-
	Class-2						42	84	-
	2K	1000	1220	2500	110	2546	41.3	82.5	0.2
	4K						51.1	103	0.4
	6K						-	-	0.6
Ø 1100	Class-1						30	65	-
	Class-2	1100	1330	2500	115	2937	44	90	-
	2K						43.2	86.4	0.2

	4K						53.0	106	0.4
	6K						-	-	0.6
Ø 1200	Class-1						31	70	-
	Class-2						46	96	-
	2K	1200	1440	2500	120	3351	45.2	90.3	0.2
	4K						55	110	0.4
	6K						-	-	0.6
Ø 1350	Class-1						32	80	-
	Class-2						48	105	-
	2K	1350	1620	2500	135	4246	47.1	94.2	0.2
	4K						58.9	118	0.4
	6K						-	-	0.6
Ø 1500	Class-1						34	90	-
	Class-2						51	114	-
	2K	1500	1796	2500	148	5167	50.1	101	0.2
	4K						62.8	126	0.4
	6K						-	-	0.6
Ø 1650	Class-1						36	100	-
	Class-2						54	122	-
	2K	1650	1972	2500	161	6225	53.0	106	0.2
	4K						66.8	134	0.4
	6K						-	-	0.6
Ø 1800	Class-1						38	110	-
	Class-2						57	131	-
	2K	1800	2146	2500	173	7293	56.0	112	0.2
	4K						70.7	142	0.4
	6K						-	-	0.6
Ø 2000	Class-1						-	-	-
	Class-2						60	142	-
	2K	2000	2380	2500	190	8922	58.9	118	0.2
	4K						75.6	152	0.4
	6K						-	-	0.6



Lining

Precast lining involves the use of pre-fabricated concrete segments or panels that are made off-site and then transported to a construction site where they are assembled into a lining for tunnels, culverts, or other underground structures. These precast elements are designed and manufactured to specific dimensions and configurations to meet the project's requirements.”

In tunnel construction, precast lining segments are frequently utilized to build tunnel linings. These segments are usually reinforced with steel and can be quickly and efficiently installed using specialized equipment. Precast lining provides advantages such as improved quality control, reduced construction time, and minimized disruption to surrounding areas compared to traditional cast-in-place concrete methods.

Lining in irrigation channels reduces water loss, prevents erosion and abrasion, inhibits the growth of aquatic plants, and decreases maintenance costs. With improved quality of irrigation flow, water distribution to fields and agriculture becomes more effective and efficient.

Technical

Type of Lining

Lining

Advantage

Precast lining offers several advantages in various construction applications, including:

- | | |
|----------------------------------|----------------------------|
| 1. Quality Control | 5. Structural Performance |
| 2. Speed of Construction | 6. Minimal Site Disruption |
| 3. Cost Efficiency | 7. Enhanced Safety |
| 4. Flexibility and Customization | 8. Environmental Benefits |

Design & Manufacturing Reference

JIS A 5335-1987	Pretensioned Spun Concrete Piles
JIS A 5373-2004	Precast Prestressed Concrete Products
JIS A 5372-2004	Precast Reinforced Concrete Products

Item	Specification	Reference
Aggregate		ASTM C33 - 2016 Standard Specification Concrete Aggregates
		SNI 8321-2016 Concrete Aggregate Specification
Cement		SNI 15-2049-2004 Portland's Cement
Admixture		ASTM C494 - 2016 Standard Specification for Chemical Admixture for Concrete
Concrete	Compressive Strength at : 28 Days : 300 kg/cm ² (Cube); 25 MPa (Cylinder)	SNI 2847-2013 Structural Concrete Requirement
Reinforced Rebar	BjTS 40 for D >= 13mm BjTS 24 for D <= 13mm	SNI 2052-2014 Concrete Reinforcement Steel Bar

Product Dimension

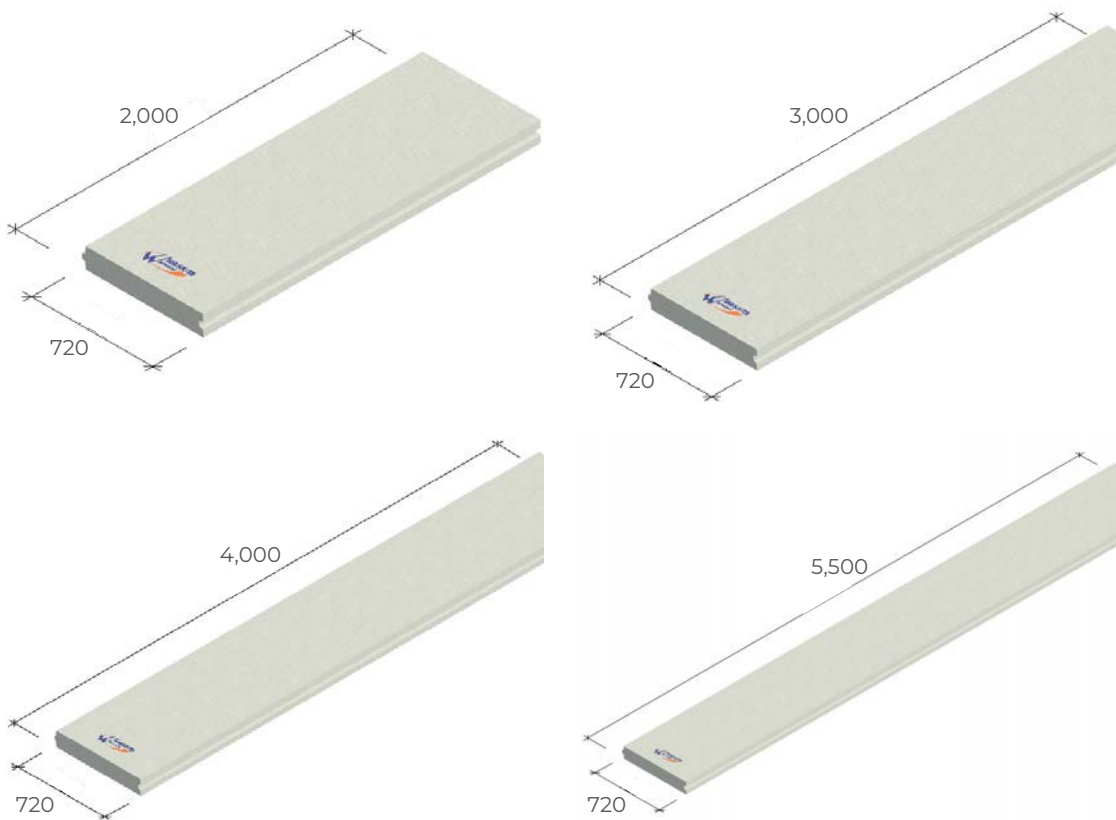



IRRIGATION





Sloof Irigasi

Sloof is a structure in a building located above the foundation and serves to distribute the load of the foundation. In this lining product, Sloof is used as the foundation to distribute and level the load from the lining (precast concrete wall) to the ground. Another equally important function of the lining's Sloof is to act as a lock for the precast concrete wall.

Sloof is a precast concrete structure that is part of an irrigation system, integrated within the precast lining product. Its function is to retain soil walls in infrastructure projects such as roads, channels, and others. Sloof is placed on the foundation and is responsible for distributing the foundation load evenly. Along with the precast concrete Lining or wall, Sloof will distribute and level the load to the subsoil and act as a channel lock.

Technical

Type of Sloof

Sloof

Advantage

Precast lining offers several advantages in various construction applications, including:

1. Quality Control
2. Speed of Construction
3. Cost Efficiency
4. Flexibility and Customization
5. Structural Performance
6. Minimal Site Disruption
7. Enhanced Safety
8. Environmental Benefits

Design & Manufacturing Reference

JIS A 5373-2004	Precast Prestressed Concrete Products
JIS A 5372-2004	Precast Reinforced Concrete Products

Specification of Source Material

Item	Specification	Reference
Aggregate	ASTM C33 - 2016	Standard Specification Concrete Aggregates
	SNI 8321-2016	Concrete Aggregate Specification
Cement	SNI 15-2049-2004	Portland's Cement



IRRIGATION

Admixture		ASTM C494 - 2016	Standard Specification for Chemical Admixture for Concrete
Concrete	Compressive Strength at: 28 Days : 300 kg/cm ² (Cube); 25 MPa (Cylinder)	SNI 2847-2013	Structural Concrete Requirement
Reinforced Rebar	BJTS 40 for D >= 13mm BJTS 24 for D <= 13mm	SNI 2052-2014	Concrete Reinforcement Steel Bar

Product Dimension

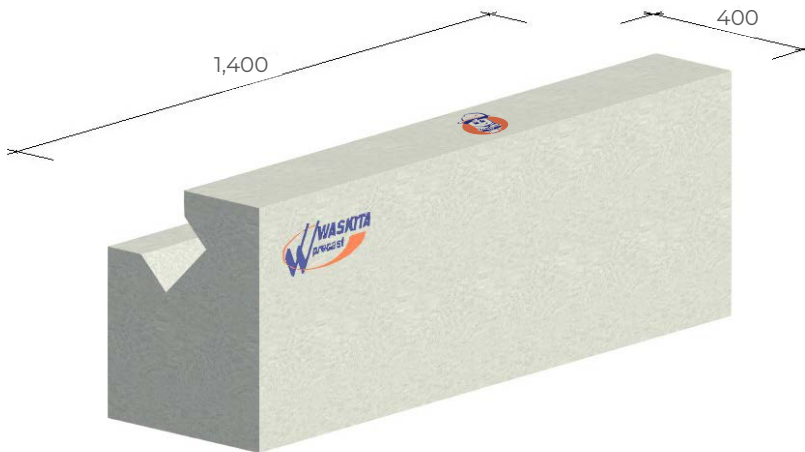





U-Ditch & Cover

Precast channels that have a rectangular cross section, are generally used as drainage channel on the road edge. Product is able to loaded with vertical load but not for very heavy loads (Like truck, or train).

Technical

Type of Production

Wet cast with high frequency vibration

Design & Manufacturing Reference

SNI 03-2847-2013

Indonesian Concrete Code

Specification of Source Material

Item	Specification	Reference
Aggregate		ASTM C33 - 2016 Standard Specification Concrete Aggregates
		SNI 8321-2016 Concrete Aggregate Specification
Cement		SNI 15-2049-2004 Portland's Cement
Admixture		ASTM C494 - 2016 Standard Specification for Chemical Admixture for Concrete
Concrete	Compressive Strength at : 28 Days : 350 kg/cm ² (Cube); 30 MPa (Cylinder)	SNI 2847-2013 Structural Concrete Requirement
Wire Mesh	JKBN A Shape	SNI 07-0663-1995 Welded Steel Wire Mesh for Concrete Reinforcement
Reinforced Rebar	BjTS 40 For D ≥ 13mm	SNI 2052-2014 Concrete Reinforcement Steel Bar
	BjTP 24 For D < 13mm	
PC Strand	KBjP-P7 RB	SNI 1154-2011 Uncoated Seven Wire Stress Relieved Standard for Prestress Concrete (Pc Strand/ KBjP-P7)

PC Strand	Grade 270	ASTM A-416	Standard Specification for Uncoated Seven Wire Stress Relieved Strand for Prestressed Concrete
	SWPR7BL	JIS G 3536 : 2014	Uncoated Stress-Relieved Steel Wires and Strands for Prestressed Concrete)

Product Dimension

Cover U-Ditch

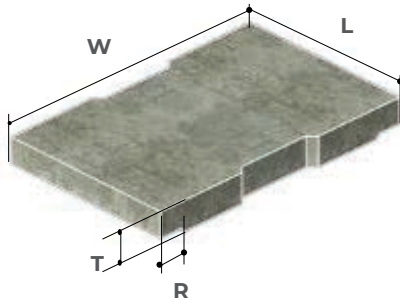

U-Ditch

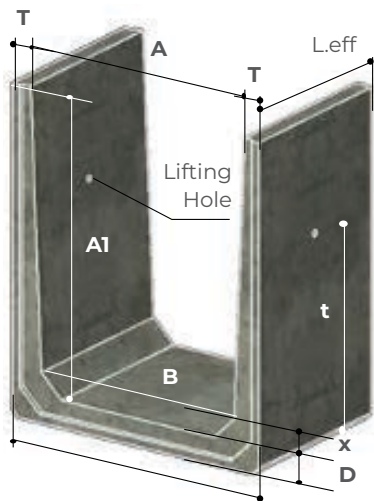

U-Ditch Dimensions	Type	U-Ditch Cover Dimensions			
		Thickness T (mm)	Width W (mm)	Length L (mm)	Notch R (mm)
U 300	A	102	390	600	55
	B	75	390	600	55
U 400	A	122	500	600	57
	B	90	500	600	57
U 500	A	132	640	600	78
	B	90	640	600	78
U 600	A	142	740	600	78
	B	100	740	600	78
U 800	A	152	940	600	78
	B	100	940	600	78
U 1000	A	152	1180	600	106
	B	120	1180	600	106
U 1200	A	152	1390	600	117
	B	120	1390	600	117
U 1400	A	180	1620	600	130
	B	150	1620	600	130
U 1600	A	200	1840	600	140
	B	180	1840	600	140

Note : A=For heavy load (Max. Axle load : 10 Ton),
B=for light load (Max. Axle load : 5 Ton)

(A x A1 x L. Eff) (mm)	Type	A (mm)	A1 (mm)	B (mm)	C (mm)	D (mm)	T (mm)	L.eff (mm)	X (mm)	Weight (kg)
300 x 200 x 1200	A	287	200	280	390	60	52	1200	40	138
300 x 300 x 1200	B	291	300	280	390	60	49	1200	40	168
300 x 300 x 1200	C	296	400	280	390	60	47	1200	40	197
300 x 400 x 1200	D	300	500	280	390	60	45	1200	40	224
400 x 300 x 1200	A	394	300	390	500	70	53	1200	70	215
400 x 400 x 1200	B	396	400	390	500	70	52	1200	70	247
400 x 500 x 1200	C	398	500	390	500	70	51	1200	70	278



IRRIGATION

400 x 600 x 1200	D	400	600	390	500	70	50	1200	70	308
500 x 300 x 1200	A	492	300	488	640	70	74	1200	70	283
500 x 400 x 1200	B	494	400	488	640	70	73	1200	70	327
500 x 500 x 1200	C	496	500	488	640	70	72	1200	70	370
500 x 600 x 1200	D	498	600	488	640	70	71	1200	70	413
500 x 700 x 1200	E	500	700	488	640	70	70	1200	70	455
600 x 400 x 1200	A	592	400	586	740	70	74	1200	70	350
600 x 500 x 1200	B	594	500	586	740	70	73	1200	70	394
600 x 600 x 1200	C	596	600	586	740	70	72	1200	70	438
600 x 700 x 1200	D	598	700	586	740	70	71	1200	70	480
600 x 800 x 1200	E	600	800	586	740	70	70	1200	70	523
800 x 600 x 1200	A	792	600	780	940	100	74	1200	70	574
800 x 700 x 1200	B	794	700	780	940	100	73	1200	70	618
800 x 800 x 1200	C	796	800	780	940	100	72	1200	70	661
800 x 1000 x 1200	D1	800	1000	780	940	100	70	1200	70	747
800 x 1000 x 1200	D2	800	1000	770	1000	100	100	1200	100	978
800 x 1200 x 1200	E	800	1200	780	940	100	70	1200	70	837
1000 x 650 x 1200	A	1000	650	980	1180	110	90	1200	70	741
1000 x 800 x 1200	B	978	800	940	1180	110	101	1200	100	955
1000 x 1000 x 1200	C1	1000	1000	940	1180	110	90	1200	100	1059
1000 x 1000 x 1200	C2	1000	1000	970	1200	100	100	1200	100	1038
1000 x 1200 x 1200	D	1000	1200	940	1180	110	90	1200	100	1185
1000 x 1400 x 1200	E	1000	1400	940	1180	110	90	1200	100	1309
1200 x 1000 x 1200	A	1165	1000	1090	1390	130	112	1200	100	1369
1200 x 1200 x 1200	B	1200	1200	1090	1390	130	95	1200	100	1469
1200 x 1400 x 1200	C	1200	1400	1090	1390	130	95	1200	100	1616
1200 x 1600 x 1200	D	1200	1600	1090	1390	130	95	1200	100	1753
1400 x 1200 x 1200	A	1336	1200	1220	1600	150	132	1200	120	1941
1400 x 1400 x 1200	B	1357	1400	1220	1600	150	121	1200	120	2094
1400 x 1600 x 1200	C	1379	1600	1220	1600	150	111	1200	120	2234
1400 x 1800 x 1200	D	1400	1800	1220	1600	150	100	1200	120	2360
1600 x 1400 x 1200	A	1548	1400	1440	1840	170	146	1200	150	2500
1600 x 1600 x 1200	B	1565	1600	1440	1840	170	137	1200	150	2650
1600 x 1800 x 1200	C	1583	1800	1440	1840	170	129	1200	150	2810
1600 x 2000 x 1200	D	1600	2000	1440	1840	170	120	1200	150	2960



Box Culvert

Precast channels that have a rectangular cross section, are generally used as crossing channel on the road or water tunnel but can be used too as a drainage channel on road edge. Product is able to loaded with vertical load such as vehicle load

Technical

Type of Production

Wet cast with high frequency vibration

Design & Manufacturing Reference

SNI 03-2847-2013

Indonesian Concrete Code

Specification of Source Material

Item	Specification	Reference
Aggregate		ASTM C33 - 2016 Standard Specification Concrete Aggregates
		SNI 8321-2016 Concrete Aggregate Specification
Cement		SNI 15-2049-2004 Portland's Cement
Admixture		ASTM C494 - 2016 Standard Specification for Chemical Admixture for Concrete
Concrete	Compressive Strength at : 28 Days : 350 kg/cm ² (Cube); 30 MPa (Cylinder)	SNI 2847-2013 Structural Concrete Requirement
Reinforced Rebar	BjTS 40 For D ≥ 13mm	SNI 2052-2014 Concrete Reinforcement Steel Bar
	BjTP 24 For D < 13mm	



Product Dimension

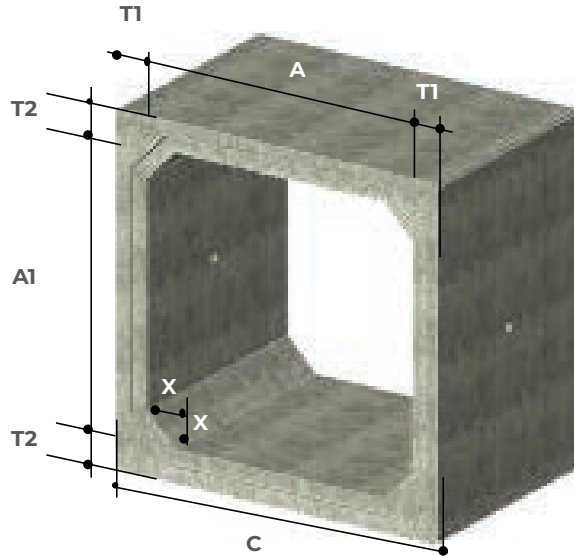

Size Wide x Depth x Length	Type	Dimensi Cover U-Ditch							Approx. Weight (kg)
		A1 (mm)	A (mm)	T1 (mm)	T2 (mm)	C (mm)	L (mm)	X (mm)	
400 x 400 x 1200	BC 400	400	400	85	85	570	1200	80	515
500 x 600 x 1200	BC 500	500	500	90	90	680	1200	85	665
600 x 600 x 1200	BC 600	600	600	95	95	790	1200	90	860
800 x 800 x 1200	BC 800	800	800	110	110	1020	1200	105	1285
1000 x 1000 x 1200	BC 1000 A	1000	1000	125	125	1250	1200	120	1760
1000 x 1500 x 1200	BC 1000 B	1000	1500	170	170	1340	1200	150	2558
1000 x 2000 x 1200	BC 1000 C	1000	2000	180	180	1360	1200	170	3185
1200 x 1200 x 1200	BC 1200	1200	1200	142	142	1484	1200	140	2430
1500 x 1500 x 1200	BC 1500	1500	1500	165	165	1784	1200	160	3600
2000 x 1000 x 1200	BC 2000 A	2000	1000	180	180	2360	1200	170	4025
2000 x 1500 x 1200	BC 2000 B	2000	1500	200	200	2400	1200	190	4818
2000 x 2000 x 1200	BC 2000 C	2000	2000	210	210	2420	1200	200	5775
2000 x 2500 x 1200	BC 2000 D	2000	2500	230	230	2460	1200	210	6865
2000 x 3000 x 1200	BC 2000 E	2000	1390	250	250	2500	1200	230	8175



Halo WSBP!



halo.waskitaprecast.co.id



HOUSING & BUILDING

Modular
i-Home

RISHA
Modifikasi

Modular
i-MOD

Rumah Precast
Tipe 36

Beam-Column
Precast

Modular
High Rise

Facade

Precast Stair

HCS
(Hollow Core Slab)

Housing & Building

Beam-Column Precast

Facade

Precast Stair

Rumah Precast Tipe 36

Risha Modifikasi

i-Mod

i-Home

MCK Precast



Beam-Column Precast

This precast building beam and column systems are more practical to do, don't need a lot of formwork and falsework, so installation time be quicker. Beam-column connection system equipped with reinforced concrete and prestressed concrete components, so the building is more ductile when facing earthquake loads.

Technical

Type of Connection

Wet Join with Unbounded Post Tension System

Compressive Strength at 28 Days

500 kg/cm² (Cube); 42 MPa (Cylinder)

Design & Manufacturing Reference

SNI 03-2847-2013	Indonesian Concrete Code
SNI 7833-2012	Design Guidelines for Precast Concrete & Prestressed Concrete for Building Structures
SNI 03-2847-2013	Indonesian Concrete Code
SNI 2847:2019	Design and Detailing Concrete Structural Detailing Concrete Structural Elements
SNI 1726:2019	Seismic Loading
SNI 7834:2012	Test method and acceptance criteria for moment-bearing precast reinforced concrete frame system for buildings

Specification of Source Material

Item	Specification	Reference
Aggregate	ASTM C33 - 2016	Standard Specification Concrete Aggregates
	SNI 8321-2016	Concrete Aggregate Specification
Cement	SNI 15-2049-2004	Portland's Cement
Admixture	ASTM C494 - 2016	Standard Specification for Chemical Admixture for Concrete

Concrete	Compressive Strength at : 28 Days : 700 kg/cm ² (Cube); 55 MPa (Cylinder)	SNI 2847-2013	Structural Concrete Requirement
Reinforced Rebar	BjTS 40 For D ≥ 13mm BjTP 24 For D < 13mm	SNI 2052-2014	Concrete Reinforcement Steel Bar

Product Dimension

Precast Beams

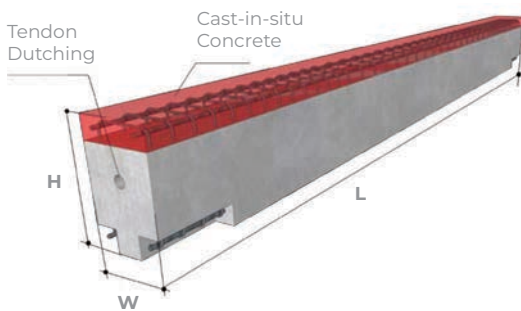

Single Precast Column

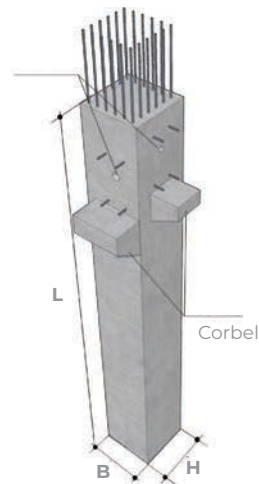

Precast Columns Continuous

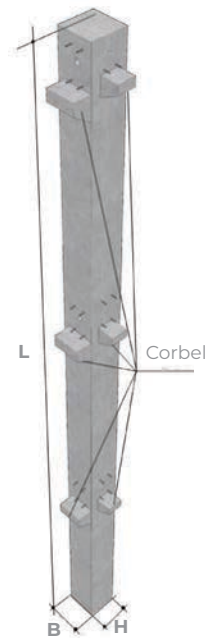

Connection System

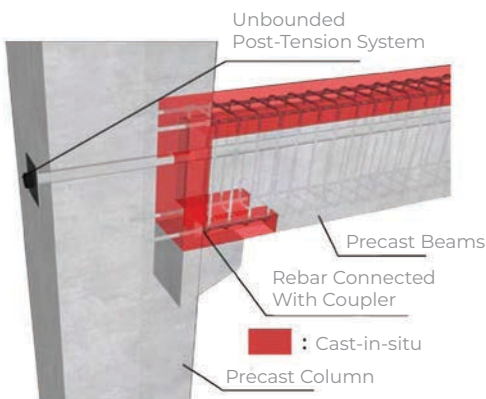

Dimension :

Beam : Beam Width & Height depends on user preference, Beam length 3-12 m

Column : Column can be produced as single column, and continuous column. Length for single column between 3-5 m, and maximum length of continuous columns 12 m



Facade

Precast concrete that used as façade of building. Easy & fast installation and less formwork & falsework.

Technical

Facade & Structural Joint

Mechanical Connection

Facade & Facade Joint

Sealant & Backup Rod

Design & Manufacturing Reference

SNI 03-2847-2013	Indonesian Concrete Code
SNI 7833-2012	Procedures for Designing Precast Concrete and Prestressed Concrete for Building Structures

Specification of Source Material

Item	Specification	Reference	
Aggregate		ASTM C33 - 2016	Standard Specification Concrete Aggregates
		SNI 8321-2016	Concrete Aggregate Specification
Cement		SNI 15-2049-2004	Portland's Cement
Admixture		ASTM C494 - 2016	Standard Specification for Chemical Admixture for Concrete
Concrete	Compressive Strength at : 28 Days : 350 kg/cm ² (Cube); 30 MPa (Cylinder)	SNI 2847-2013	Structural Concrete Requirement
Wire Mesh	JKBN Bentuk A	SNI 07-0663-1995	Welded Steel Wire Mesh for Concrete Reinforcement
Reinforced Rebar	BjTS 40 For D ≥ 13mm	SNI 2052-2014	Concrete Reinforcement Steel Bar
	BjTP 24 For D < 13mm		

Product Dimension

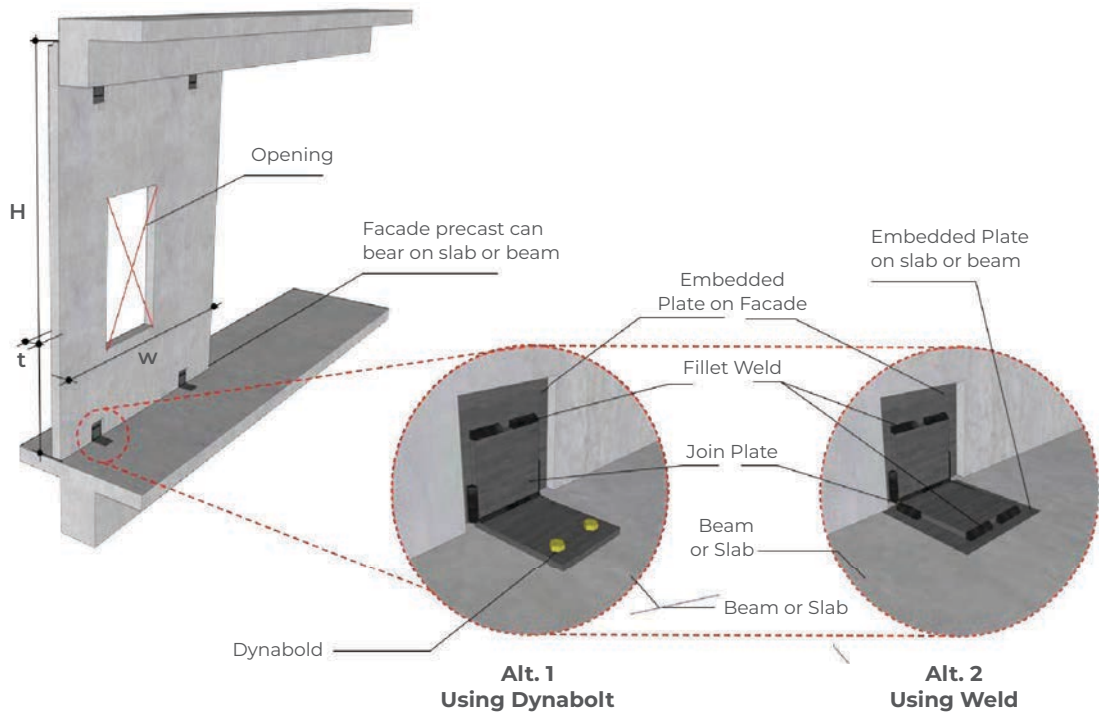

H & W dimension determined based on building facade, with limitation 5 m on Width (W) and 3,6 m on Height(H) and Lifting Equipment SWL

Thickness Recommendation (t) = 10 cm

Opening can be determined by consumer's need



Modern Precast House

Modern Precast House is a construction system invention designed for residential houses. It is built from several precast components, including foundations, columns, beams, and sills, which are fabricated or precast. For the wall components, materials such as Facade, Acotec Hollow Core, Hebel, or lightweight bricks can be used.

Design & Manufacturing Reference

Structure	RISHA Structure Components
Wall	Lightweight Brick Walls
Frames	Meranti Wood and Aluminum Frames
Ceiling	Hollow Frame with Gypsum Board Covering
Roof Frame	Lightweight Steel Roof Frame
Roof Covering	Metal Tiles
Flooring	Main Area 40x40 cm Ceramic Tiles, Toilet 20x20 cm
Sanitary Type	Squat Toilet, Soak Pit, Septic Tank

Design & Manufacturing Reference

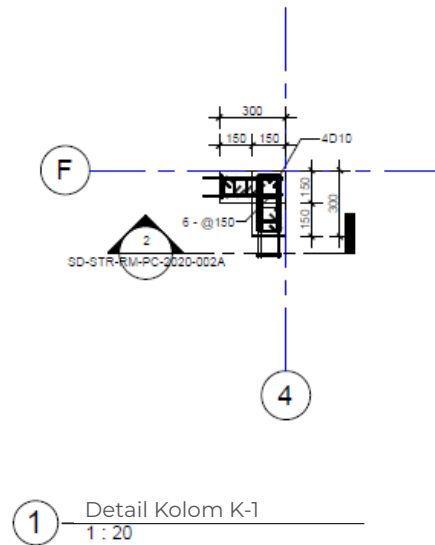
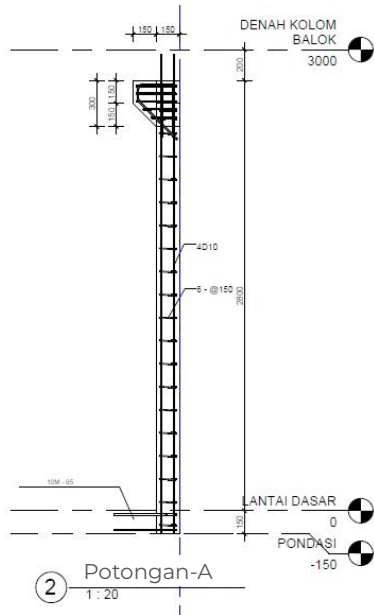
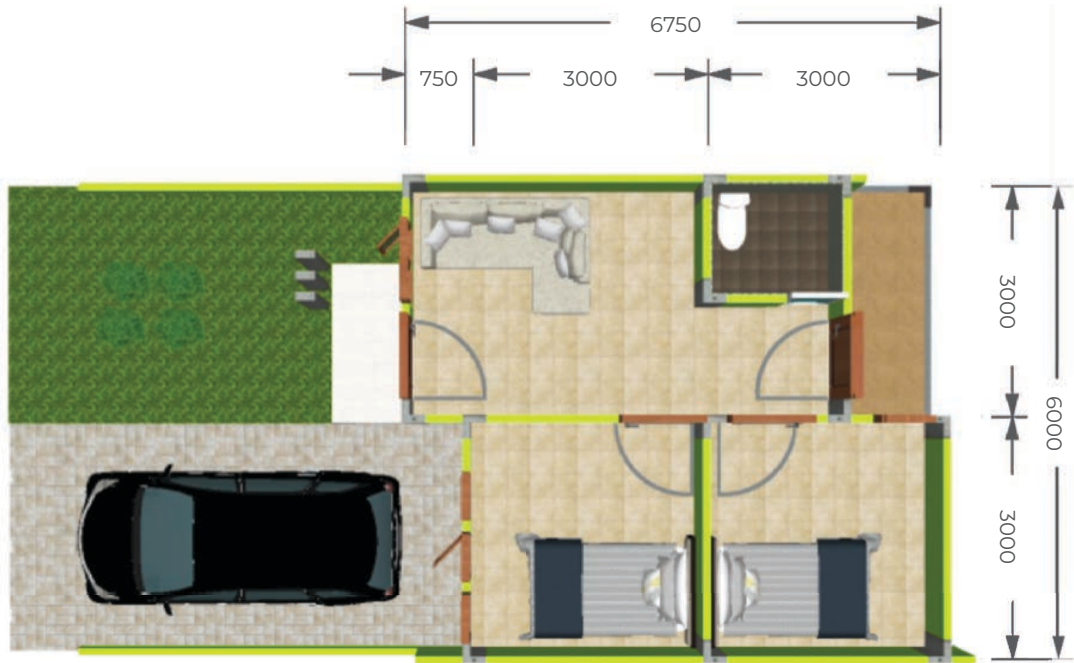

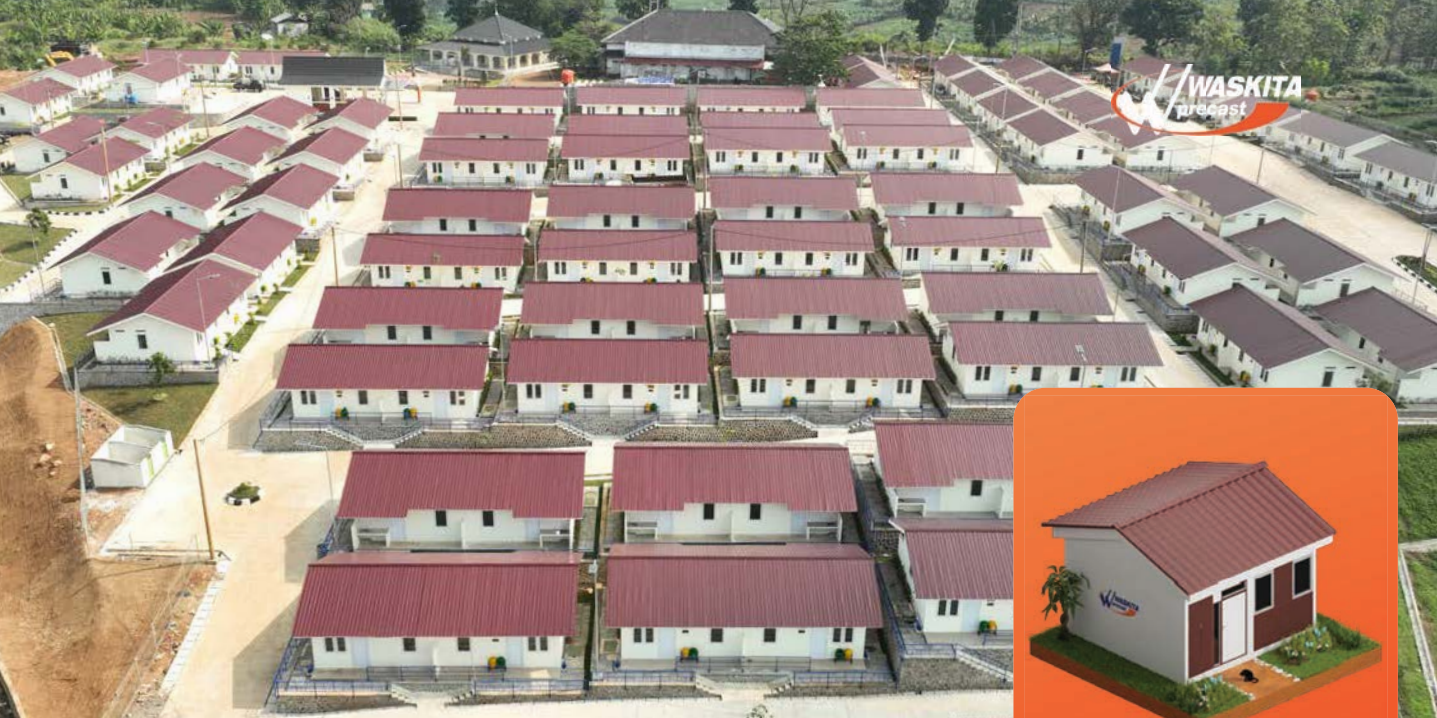

Modified RISHA

Rumah Instan Sederhana Sehat (RISHA) is a building construction system invented by the Research and Development Agency (Balitbang) of the Ministry of Public Works and Housing (PUPR). The Modified RISHA Type 36 House is a result of design modifications by PT Waskita Beton Precast Tbk, giving it a more modern and futuristic appearance.

Design & Manufacturing Reference

Structure	Precast Foundation, Beams, Sloof, and Columns Precast
Wall	Acotec Hollow Core & Hebel Walls, Plastering & Paint Finish
Frames	Meranti Wood and Aluminum Frames
Ceiling	Hollow Frame with Gypsum Board Covering
Roof Frame	Lightweight Steel Roof Frame
Roof Covering	Metal Tiles
Flooring	Main Area 40x40 cm Ceramic Tiles, Toilet 20x20 cm
Sanitary Type	Squat Toilet, Soak Pit, Septic Tank



Design & Manufacturing Reference

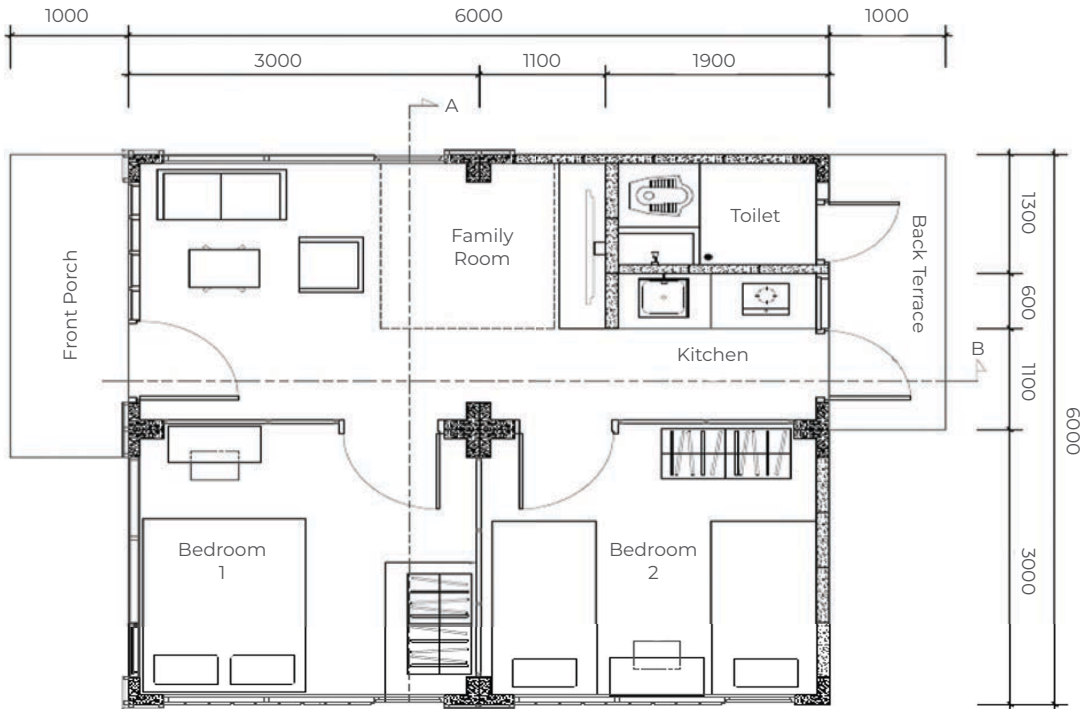

Panel Components RISHA

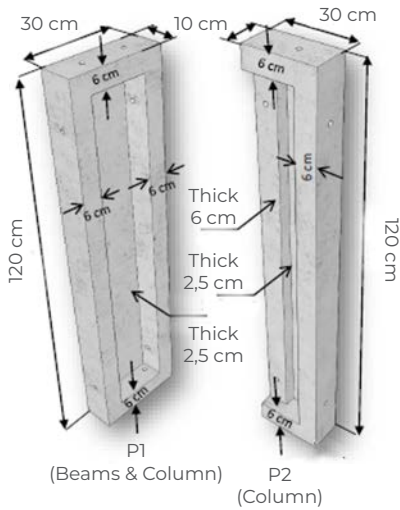

Panel Joints

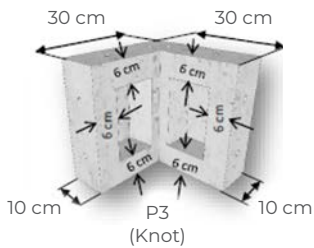
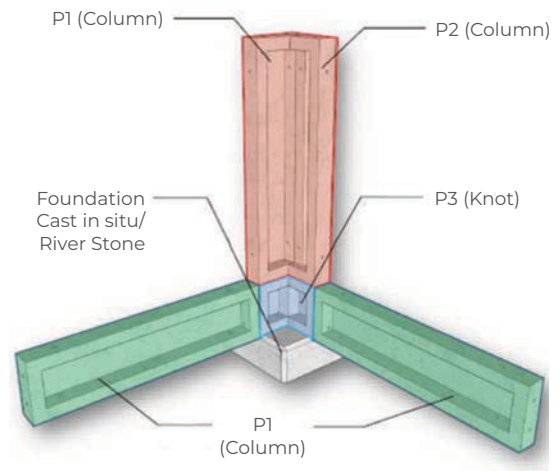

Reference: RISHA PU Book, Chapter 2.1

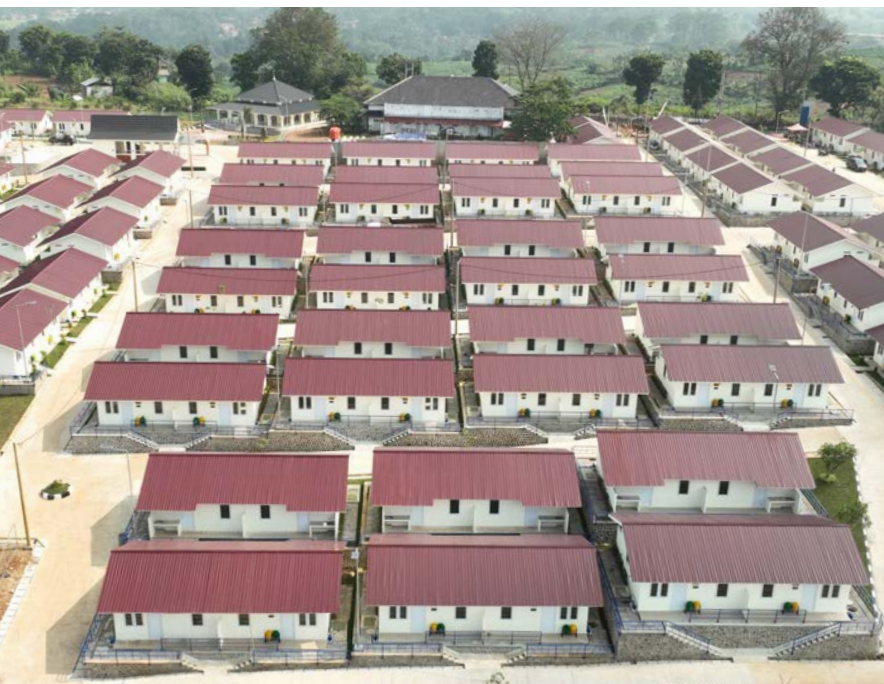



Modular i-MOD

Technical Specification

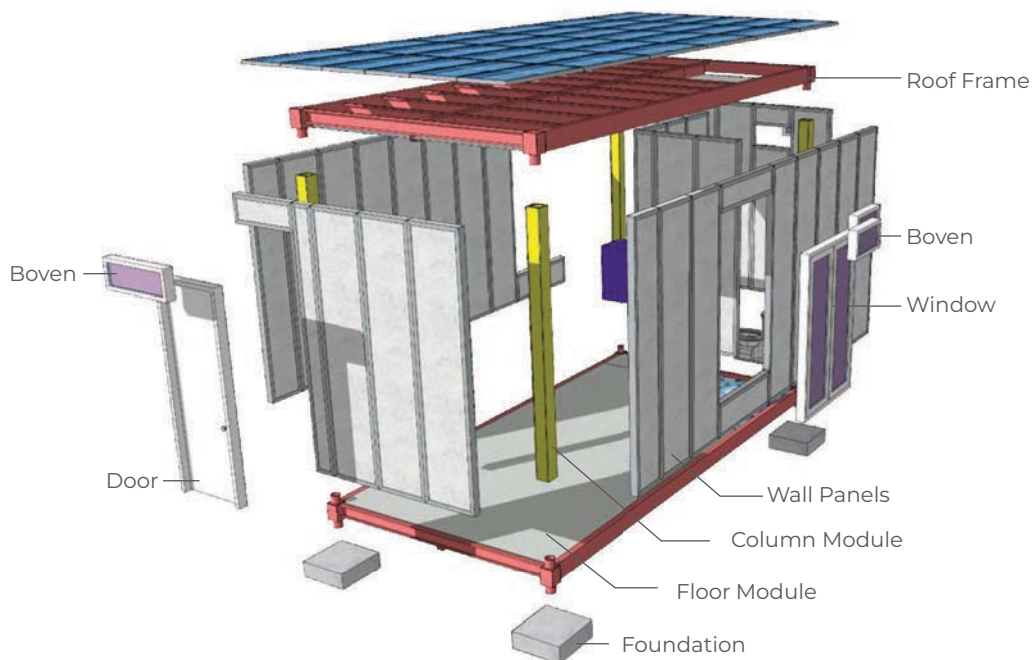

Modular Steel Components:

1. Floor Module:

- 15mm GRC floor with steel frame profile
- AAC floor for the bathroom

2. Column Module:

- 100x100mm hollow steel pipe with M12 bolt connections

3. Walls:

- 100mm GRC sandwich panel with M12 bolt

4. Foundation:

- 600x600x20mm foot plate beneath the column

5. Door & Window Frames:

- UPVC

6. Roof:

- PVC ceiling with solar panels

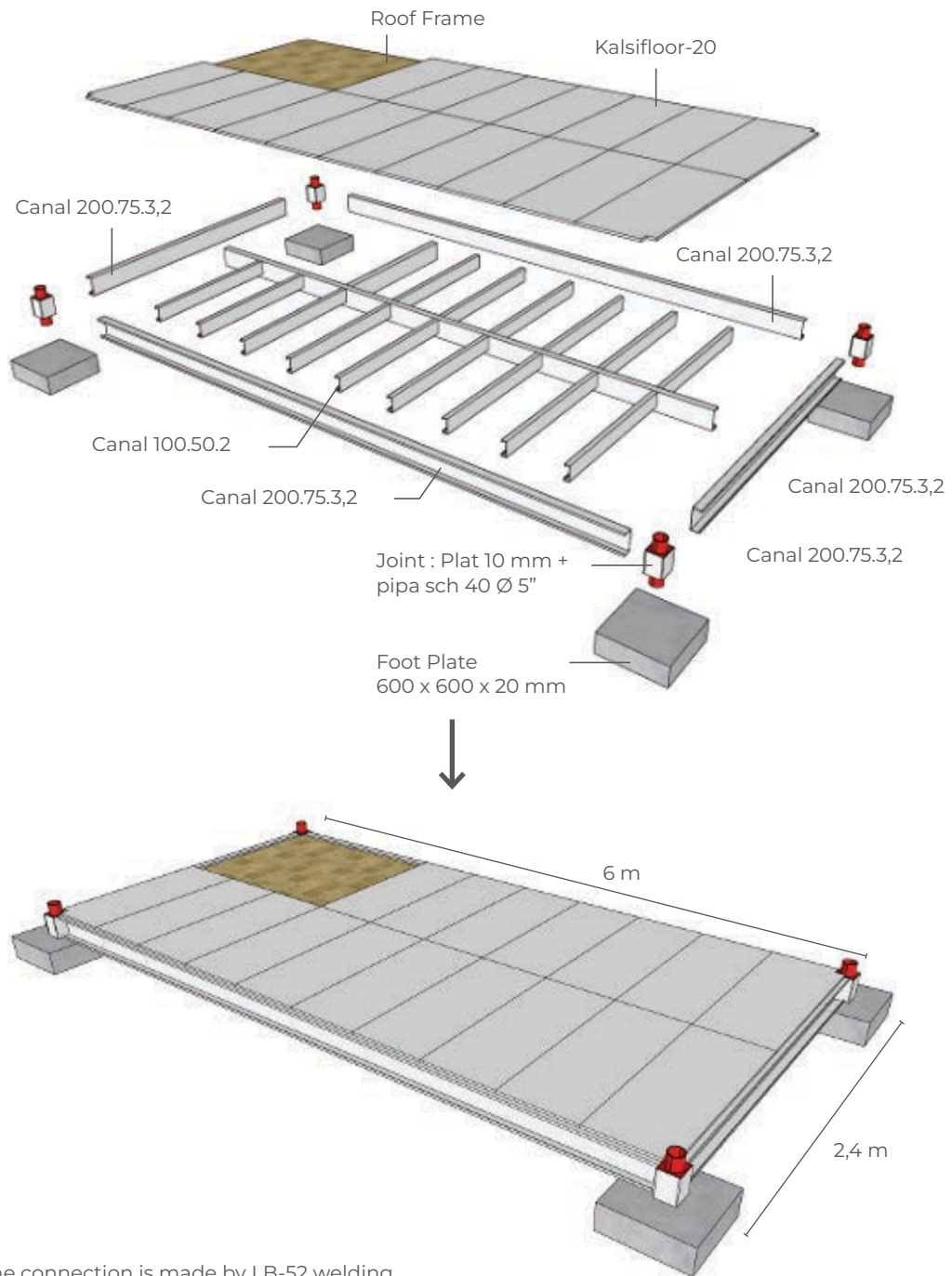

The connection is made by LB-52 welding.



Typical House Layout

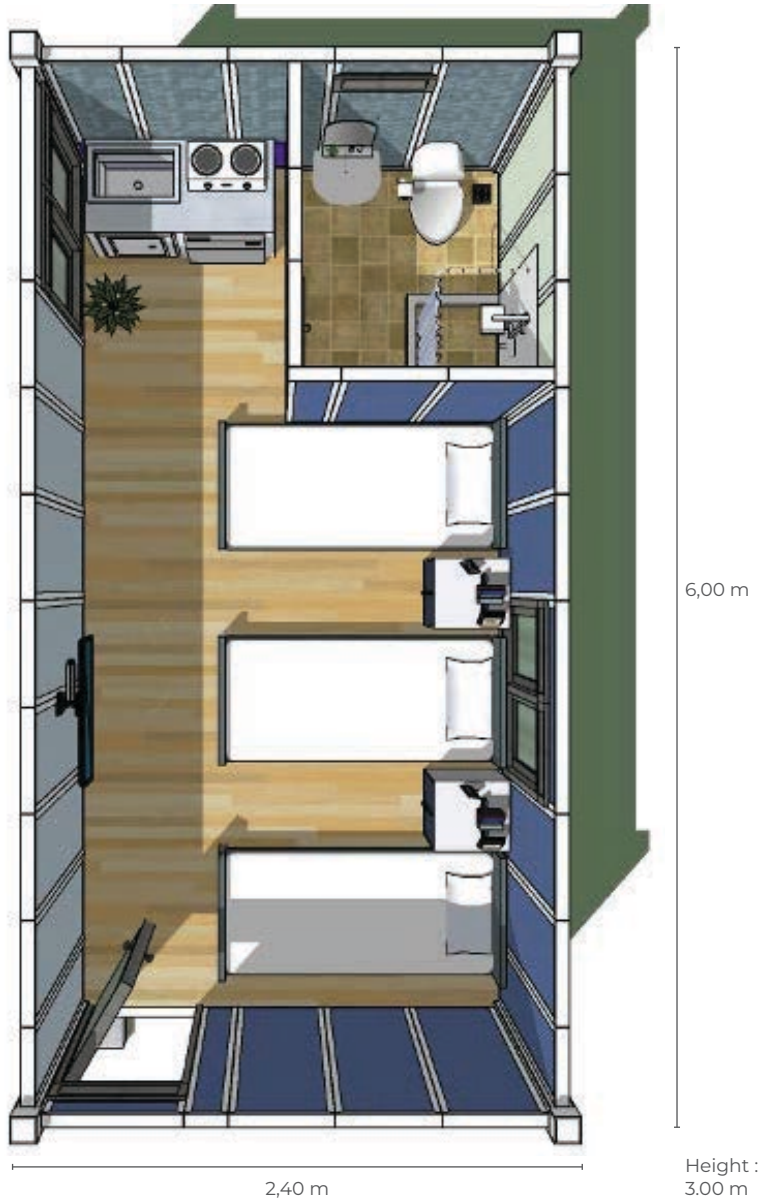

Layout Description:

- 1. Beds:**
3 Sets (Size 2.00 x 1.80 m)
- 2. Bathroom:**
1 Unit (Shower, Toilet, Sink)
- 3. Mini Kitchen Set:**
1 Set (Sink, Stove, Cabinet Rack)
- 4. Wardrobes:**
2 Sets
- 5. Doors:**
2 Sets (Main Door & Bathroom Door)
- 6. Windows:**
2 Sets
- 7. Ventilation Grilles (Boven):**
4 Sets
- 8. Exhaust Fan**
1 Set
- 9. Air Conditioner (AC) 1 PK:**
1 Unit
- 10. Television:**
1 Unit
- 11. LED Lights:**
3 Sets (2 in the Main Room & 1 in the Bathroom)

Typical House Layout

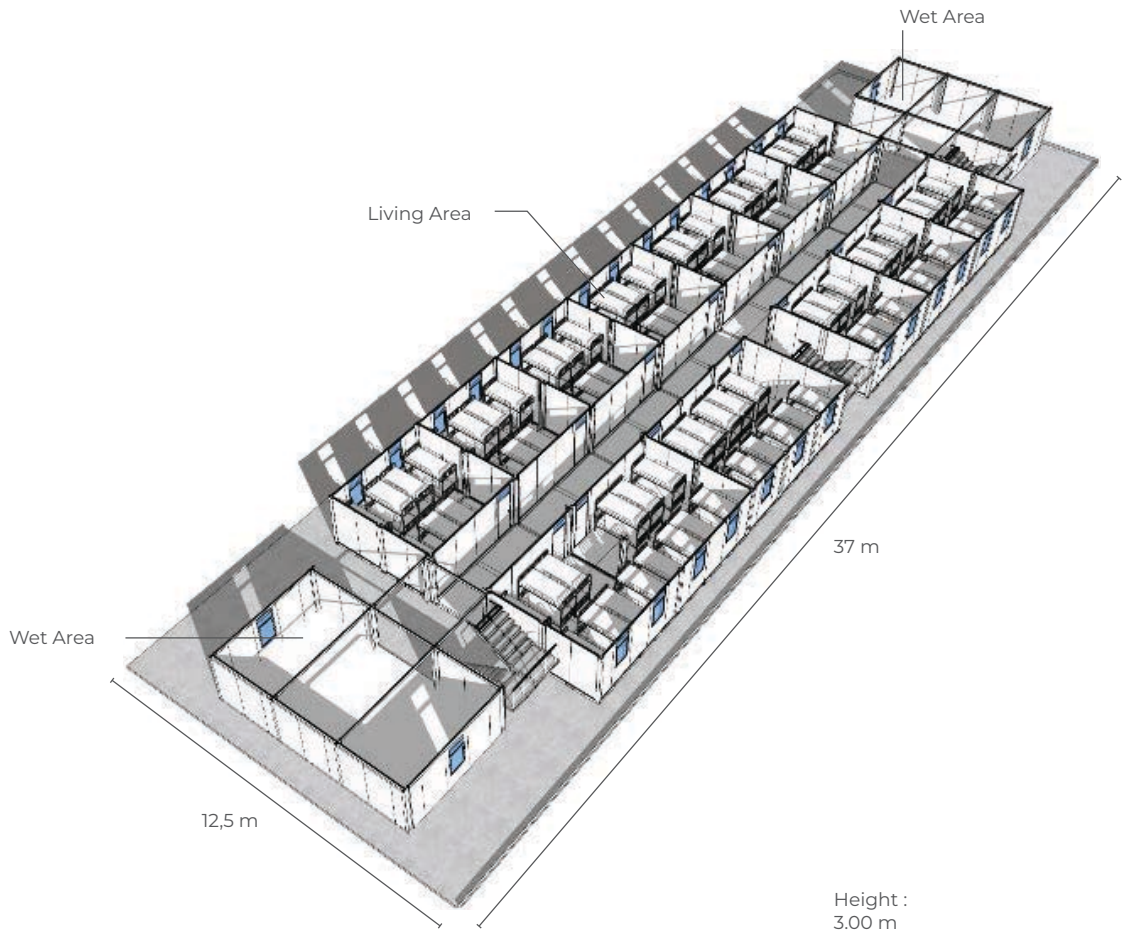

Layout Description:

- 1. Bunk Beds:**
95 units per floor, 380 units total
- 2. Bathrooms:**
24 units per floor, 96 units total
(Shower, Toilet, Sink)
- 3. Doors:**
14 sets per floor, 56 sets total
- 4. Windows:**
31 sets per floor, 124 sets total
- 5. LED Lights:**
55 points per floor, 220 points total



3D Visualization

1 Floor



2 Floor





4 Floor Mess



Packing List Unit Hunian

No Parts	Parts Name	Amount		Unit Weight		Total Weight	
		Pcs	Ton	Kg	Ton	Kg	
1	Foot Plate	4	0	169	1	675	
2	Floor Panels	1	2	1,581	2	1,581	
3	Column	4	0	50	0	199	
4a	Wall-1 (600x2800)	23	0	63	1	1,460	
4b	Wall-2 (450x2800)	3	0	48	0	143	
4c	Wall-3 (520x2800)	1	0	55	0	55	
4e	Wall-4 (250x2800)	1	0	18	0	36	
4f	Wall-5 (1200x300)	2	0	14	0	27	
4g	Wall-6 (1200x400)	2	0	18	0	18	
4h	Wall-7 (800x300)	1	0	9	0	9	
4i	Wall-8 (600x2200)	1	0	50	0	50	
4j	Wall-9 (600x600)	1	0	14	0	14	
4k	Wall-10 (600x300)	1	0	7	0	7	

4	Wall-11 (300x2800)	1	0	32	0	32
5	Wall	2	0	17	0	34
6	Boven	6	0	3	0	18
7	Door-1	1	0	10	0	10
8	Door-2	1	0	10	0	10
9	Roof Panels	1	1	1,072	1	1,072
10	Solar Panel 100 WP	36	0	8	0	279
11	PowerWall	1	0	160	0	160
Total		3.41	3,407	5.88	5,888	

Part Illustration

1 Floot Plate

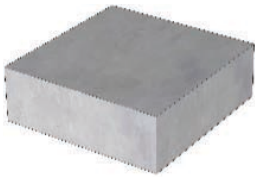

2 Floor Panels

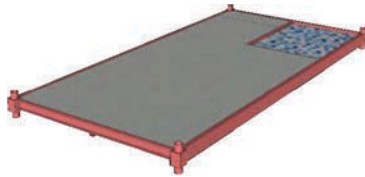

3 Column



4 Wall Panels



5 Wall



6 Boven

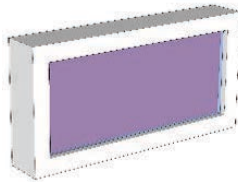

7 Door-1



8 Door-2



9 Roof Panels



11 Powerwall



10 Solar Panel





Packaging & Delivery

TOP VIEW

Assembly View-2

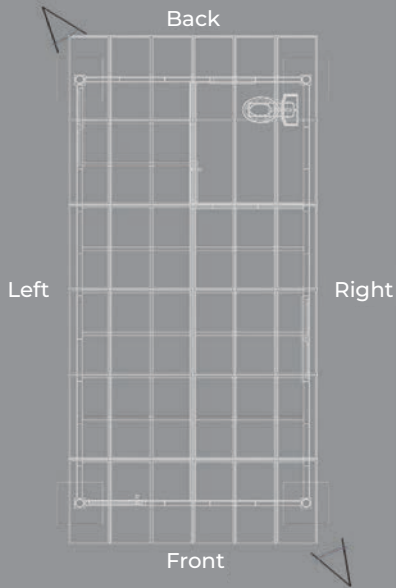

Assembly View-1

NOTES:

- Number attached in picture is parts number
- Orientation of building follow top view

Assembly View-1:

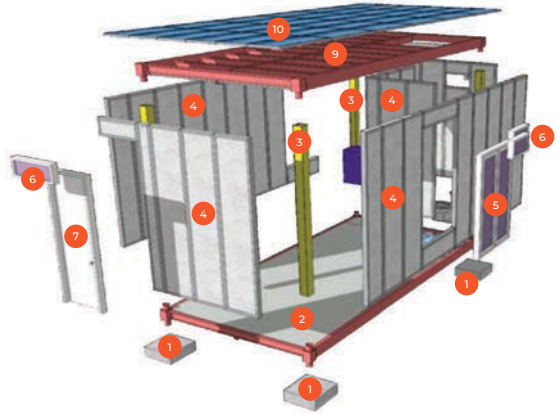

Assembly View-2:

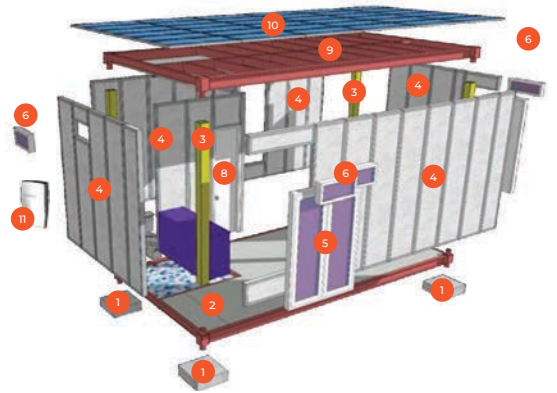

Delivery Illustration:

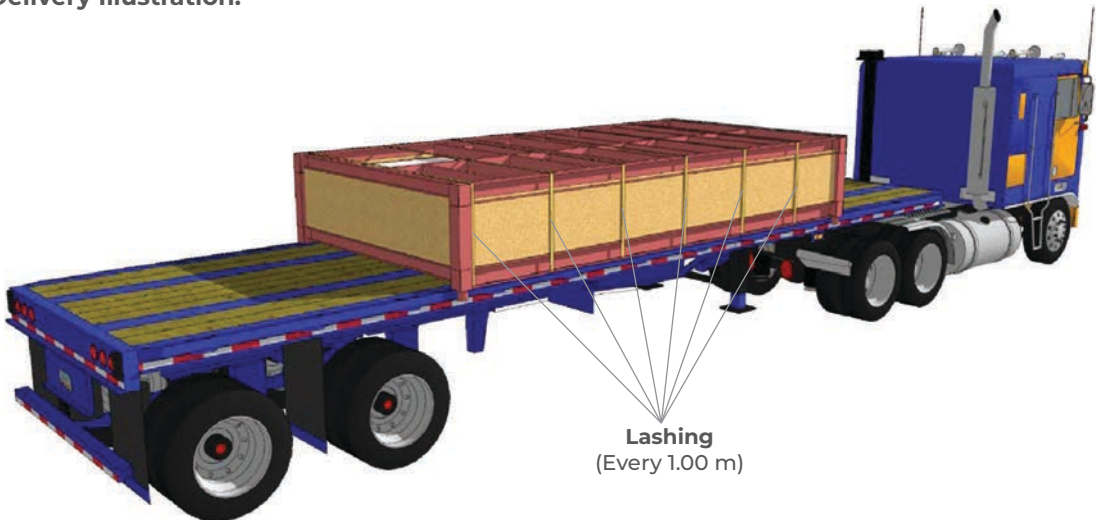

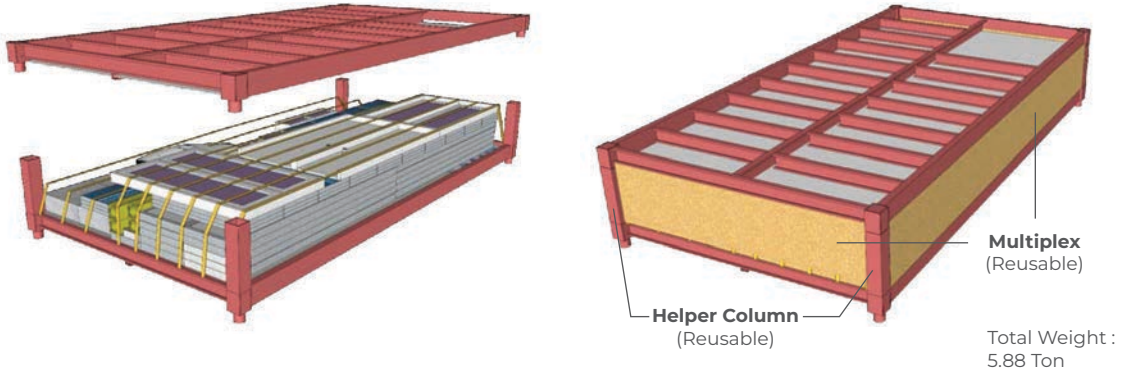

Installation Steps

1 Install Floor Panels

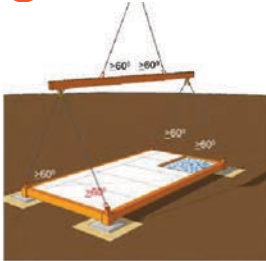

2 Install Column

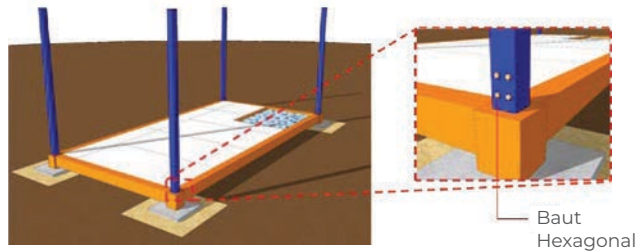

3 Wall Installation

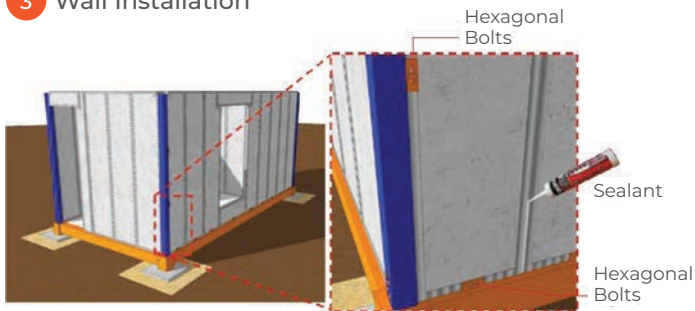

4 Install Doors & Windows



5 Install Roof Panels

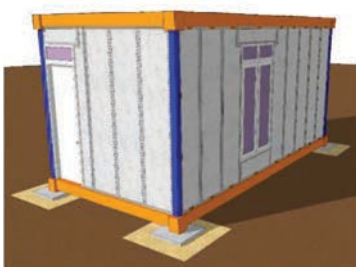

6 Water Installation

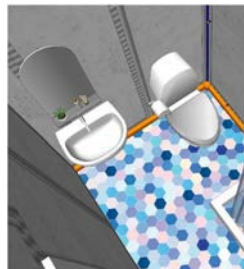

7 Electrical Installation

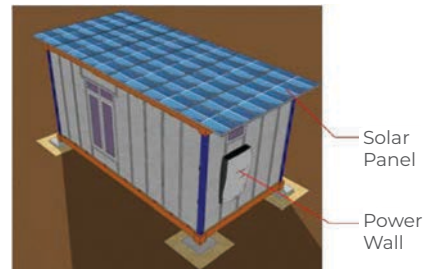



Installation Simulation of 1 Residential Unit

No	Work Items	Duration (minutes)	Amount	Total Duration (minutes)
1	Floor Panel Installation	30	1	30
2	Column Installation	15	4	60
3	Wall Installation	15	36	540
4	Door and Window Installation	30	6	180
5	Roof Panel Installation	45	1	45
6	Toilet and Shower Installation	30	2	60
7	Solar Panel Installation	180	1	180
8	Electrical Installation	240	1	240
			Total	1335 Minutes
				22,25 Hours
				2,78 Days

Assumptions:

1. Workers : 2 craftsmen, 1 lifting and transporting team
2. Work Duration : 8 hours per day



Modular i-Home

WSBP Modular House



Environmentally Friendly



Faster Construction Time



Lightweight Materials



Water and Moisture Resistant



Fire Resistant



Sound and Heat Insulation

Specification

Wall

Sandwich Panel Beton Fiber 100mm

Roof

Light steel with metal sand roof

List Plank

Glass Fiber Reinforced Cement Plank

Floor

Plaster

Ceiling

Glass Fiber Reinforced Cement board 20 mm

Window

Aluminium frame, wooden frame with 5mm clear glass

Door

Aluminium frame, double multiplex 4mm

Electrical

6 light points & 4 sockets

Bathroom

20 x 20 ceramic floor, 20 x 25 ceramic wall, sitting closet

Item	Unit	Value
Impact Test	Joule	147
Fire Resistance	Menit	120
Sound Absorbtion	db	127



Installation Stages

Work Items	Day -					
	1	2	3	4	5	6
1. Foundation						
a. Enclosure	█					
b. Pouring	█					
2. Panel Work						
a. Install thread templates	█	█	█	█		
b. Set panels	█	█	█	█		
c. Install door and window frames		█	█	█		
3. Roof			█	█	█	
4. Electrical				█	█	█
5. Plumbing				█	█	█
6. Finishing						
a. Install ceramic tiles				█	█	█
b. Painting						█

Installation Productivity: **6 days per unit ready for occupancy**

Connection Methods

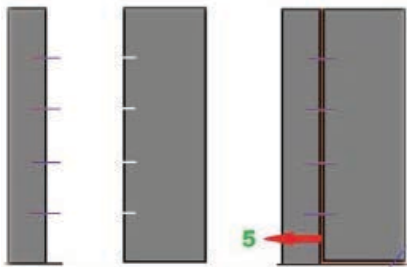

Column Connections

- Secured with **anchors** @ 500mm
- Bonded with **adhesive mortar**

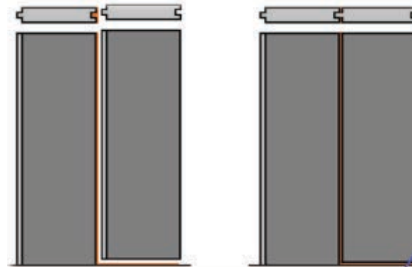

Panel-to-Panel Connections

- Bonded with **mortar**
- Mechanically secured with **U-bars, termite nails, and anchors** (118 PT)



Corner Connections

Connections are made by creating a **“key”** on the panel

Readymix Concrete



READYMIX CONCRETE



Readymix Concrete

PT Waskita Beton Precast Tbk operates dedicated Batching Plants in several area at Indonesia.

All concrete is manufactured relevant with ASTM standards. Our Readymix serve all the variant of concrete that can be seen on table.

Concrete Class	Grade			Usage
	Cylinder	Cube	Flexural	
A	FC' 40	K-500	-	Generally used for concrete structure such as : Concrete Prestress, piles, pier head structures, and other
A2	FC' 35	K-400	-	
B	FC' 30 (SL 12 ± 2)	K-350	-	Generally used on concrete structure such as : Column, beam, diaphragm, borepile, and other
B2	FC' 30 (SL 16 ± 2)	K-350	-	
C	FC' 20	K-250	-	Generally used for unreinforced concrete, such as : siklop concrete, sidewalk, housing, and other
D	FC' 15	K-175	-	
E	FC' 10	K-125	-	Generally used on : workshop floor, and lean concrete
P	-	-	FS-45	Rigid Pavement

Source : Bina Marga Standards
Not limited on table specification, other class can be designed and produced

Type of slump : Slump 0 cm to flow slump 60 cm

We can also produce special concrete such as :

- Fiber Concrete (lightweight concrete with fiber reinforced)
- High strength concrete (K 500 to K 1000)
- Fastcrete (Concrete that can dry fast, demoulded earlier, accelerate your progress project)
- Porous Concrete (for green sidewalk that can infiltrate water faster)

Other grade or specification can be produced based on user needs.



Our Typical Batching Plant Capacity :

- 60 m³ /hour and 90 m³ /hour that spread throughout Indonesia.
- We are ready to make dedicated Batching Plant for customer's project wherever project located if minimum contract value are matched.

Dedicated Batching Plant Facilities :

Batching Plant Computer Controlled, wet system Laboratorium at Plant Are (with Compressive test machine that always calibrated yearly) Truck Mixer, Concrete Pump



Sales Area

Area 1

- 📍 Jl. Radial, Komplek Ruko Transmart No. 5A, 24 Ilir, Bukit Kecil Palembang 30134
- ✉️ area1@waskitaprecast.co.id

Area 2

- 📍 Jalan Cawang Baru RT 08 RW 09 No. 17 Cipinang Cimpedak Jatinegara, Jakarta Timur 13340
- ✉️ area2@waskitaprecast.co.id

Area 3

- 📍 Central Java, DI Yogyakarta, Jawa Timur, Bali, NTB, NTT. Jl. Jemursari Selatan II No. 2A-2B, Jemur Wonosari, Surabaya
- ✉️ area3@waskitaprecast.co.id

Area 4

- 📍 Komplek Balikpapan Baru RT.19 Blok F3 Mandiri Ontario No.21, Kota Balikpapan, East Kalimantan 76125
- ✉️ area4@waskitaprecast.co.id

Area 5

- 📍 Jalan Pendidikan 7, kompleks UNM blok E2 no 4a, kecamatan Rappocini, Kota Makassar, South Sulawesi
- ✉️ area5@waskitaprecast.co.id

For Construction & Installation Inquiry

- 📍 Vasaka Building 5th Floor, Jl. MT Haryono Kav, No.10A, Cawang, Jakarta Timur 13340
- ✉️ pemasaran_2@waskitaprecast.co.id



HALO WSBP!

halo.waskitaprecast.co.id



Halo WSBP!



halo.waskitaprecast.co.id

PT Waskita Beton Precast Tbk
(Ticker Code: WSBP)

Vasaka Building 5th Floor
Jl. MT Haryono Kav. No. 10A, Jakarta Timur 13340

- | | |
|----------------------------------------------------------------------------------------------------------|-------------------------------------------------------------------------------------------------------------------|
|  @WSBP |  BelajarBeton.com |
|  @waskita_precast |  free3DBIM-produkwsbp.com |
|  @waskita_precast |  eproc.waskitaprecast.co.id |
|  waskitaprecast.co.id |  investor.waskitaprecast.co.id |